

**INNERFACE  
ARCHITECTURAL  
SIGNAGE, INC.**

**DIRECTING  
PEOPLE  
BY DESIGN**

**ARO**  
SERIES



**SPECIFICATIONS**

5849 PEACHTREE ROAD  
ATLANTA, GEORGIA 30341  
T 770 921 5566  
T 800 445 4796  
F 770 279 1327  
INNERFACESIGN.COM

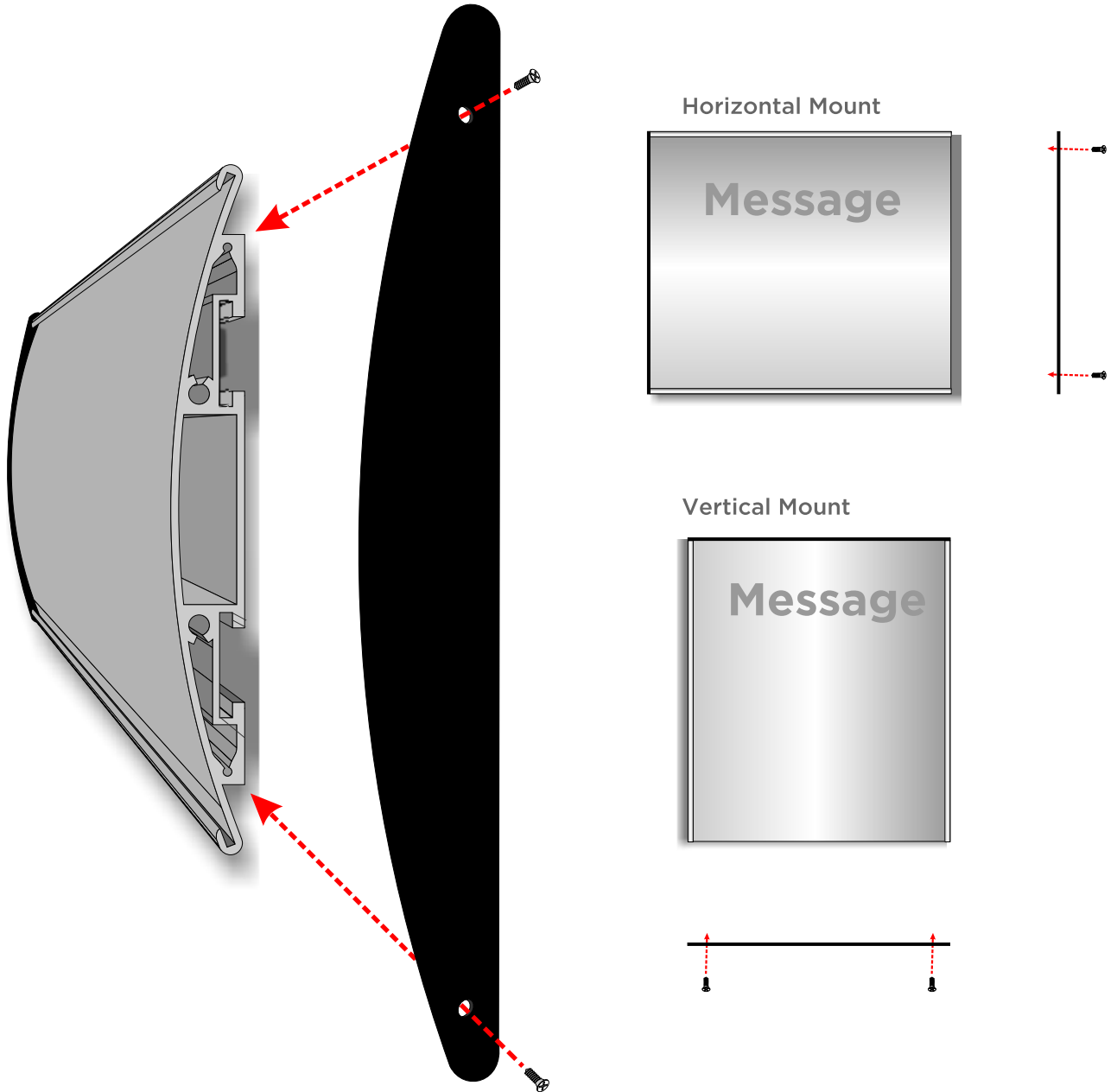

## Interior

This drawing and the ideas expressed remain the confidential property of INNERFACE. This drawing and its ideas are not to be reproduced, copied, or disclosed to any other person or entity without the express written consent of a representative or agent of INNERFACE.

A

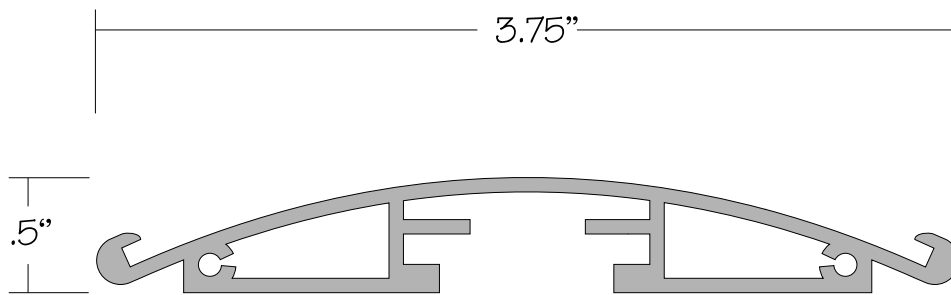

**A** 3.75" NTS

**Height:** 1.0 - 2.25"  
2.0 - 3.75"  
2.11 - 3.75"  
2.22 - 3.75"

### Interior

This drawing and the ideas expressed remain the confidential property of INNERFACE. This drawing and its ideas are not to be reproduced, copied, or disclosed to any other person or entity without the express written consent of a representative or agent of INNERFACE.

B

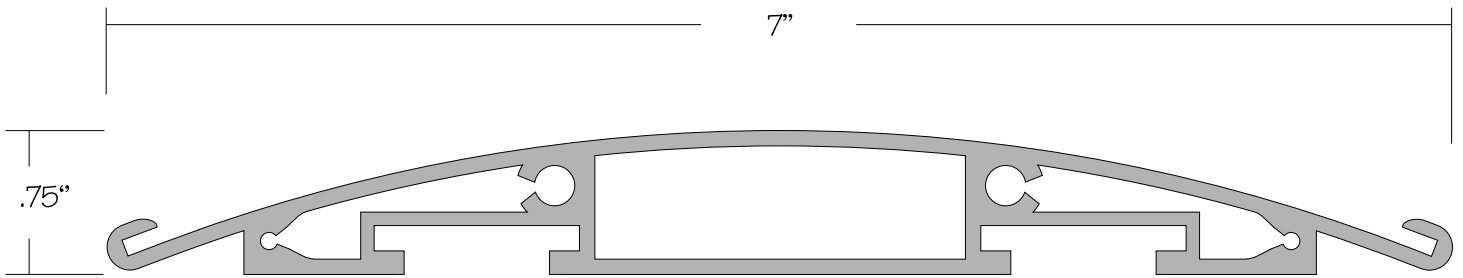

**B** 7"

NTS

**Height: 3.0 - 2.25"**  
**3.7 - 4.5"**  
**4.0 - 7.00"**  
**4.11 - 7.00"**  
**4.22 - 7.00"**  
**4.33 - 7.00"**  
**4.44 - 7.00"**  
**4.6 - 7.00"**  
**4.7 - 7.00"**  
**7.0V - 11.75"**

**Interior**

This drawing and the ideas expressed remain the confidential property of INNERFACE. This drawing and its ideas are not to be reproduced, copied, or disclosed to any other person or entity without the express written consent of a representative or agent of INNERFACE.

C

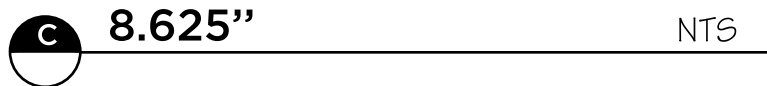
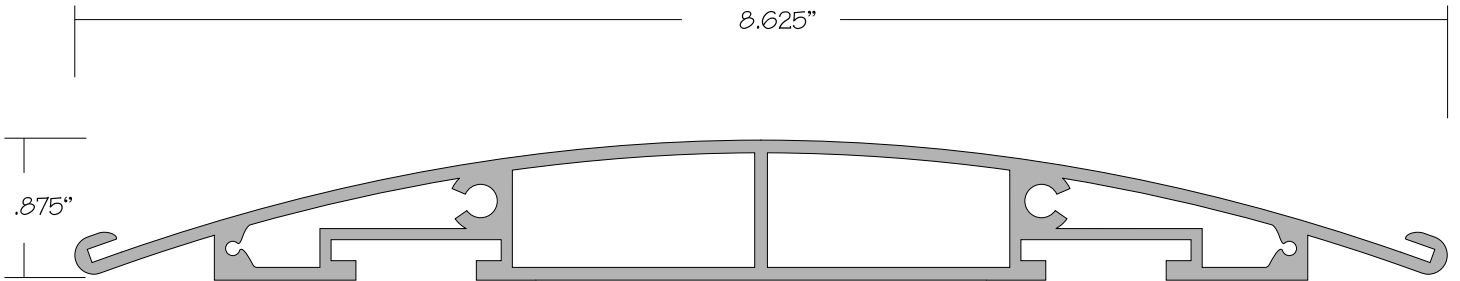

<b>Height:</b>	<b>5.0</b>	<b>-</b>	<b>2.25"</b>
	<b>5.5</b>	<b>-</b>	<b>4.50"</b>
	<b>5.6</b>	<b>-</b>	<b>4.50"</b>
	<b>6.0</b>	<b>-</b>	<b>8.625"</b>
	<b>6.11</b>	<b>-</b>	<b>8.625"</b>
	<b>6.22</b>	<b>-</b>	<b>8.625"</b>
	<b>6.33</b>	<b>-</b>	<b>8.625"</b>
	<b>6.44</b>	<b>-</b>	<b>8.625"</b>
	<b>6.6</b>	<b>-</b>	<b>8.625"</b>
	<b>8.11</b>	<b>-</b>	<b>11"</b>
	<b>8.12</b>	<b>-</b>	<b>13.375"</b>

**Interior**

This drawing and the ideas expressed remain the confidential property of INNERFACE. This drawing and its ideas are not to be reproduced, copied, or disclosed to any other person or entity without the express written consent of a representative or agent of INNERFACE.

D

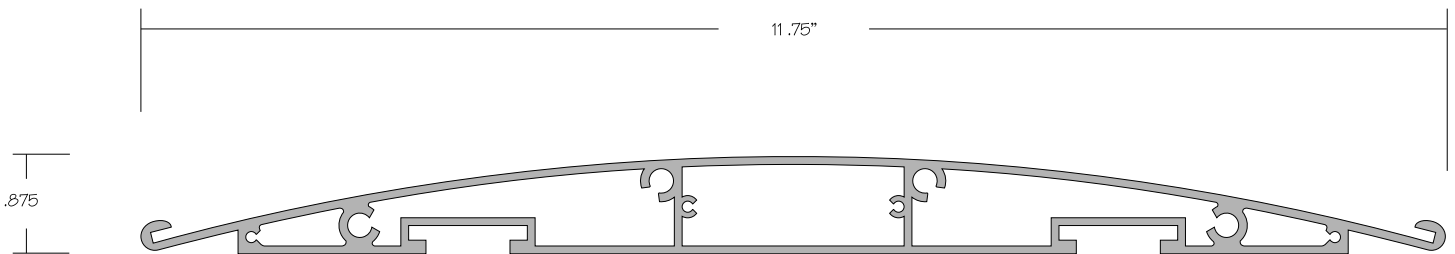

**D** 11.75" NTS

<b>Height:</b>	7.0	-	7.00"
	7.1	-	7.00"
	8.0	-	11.75"
	8.6	-	11.75"
	10.0	-	10.0"
	11.0	-	15.875"
	12.0	-	21.75"
	13.0	-	27.875"
	29.0	-	13.125"

### Interior

This drawing and the ideas expressed remain the confidential property of INNERFACE. This drawing and its ideas are not to be reproduced, copied, or disclosed to any other person or entity without the express written consent of a representative or agent of INNERFACE.

E

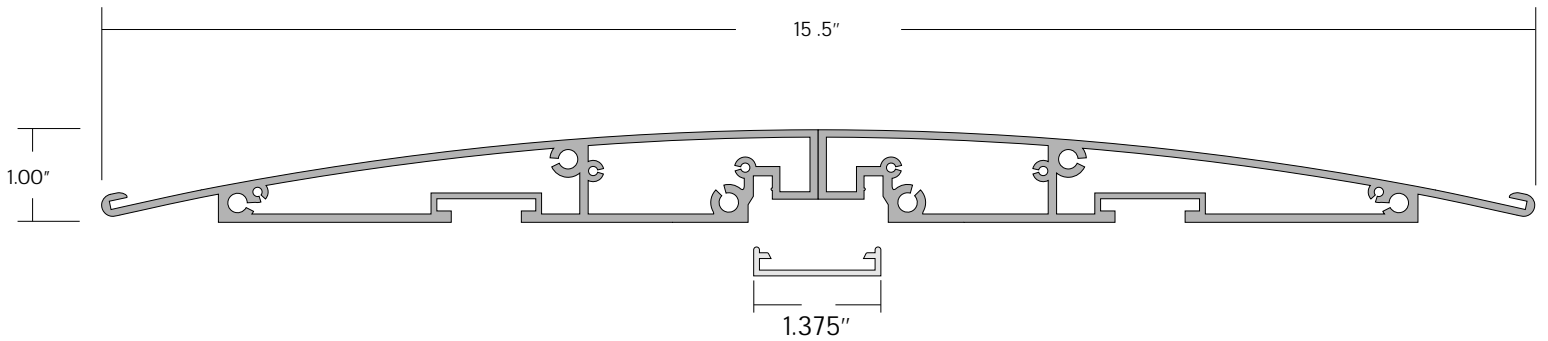

**E** **Width 15.5"** **NTS**

**Height: 9.0 - 15.5"**

### Interior

This drawing and the ideas expressed remain the confidential property of INNERFACE. This drawing and its ideas are not to be reproduced, copied, or disclosed to any other person or entity without the express written consent of a representative or agent of INNERFACE.

F

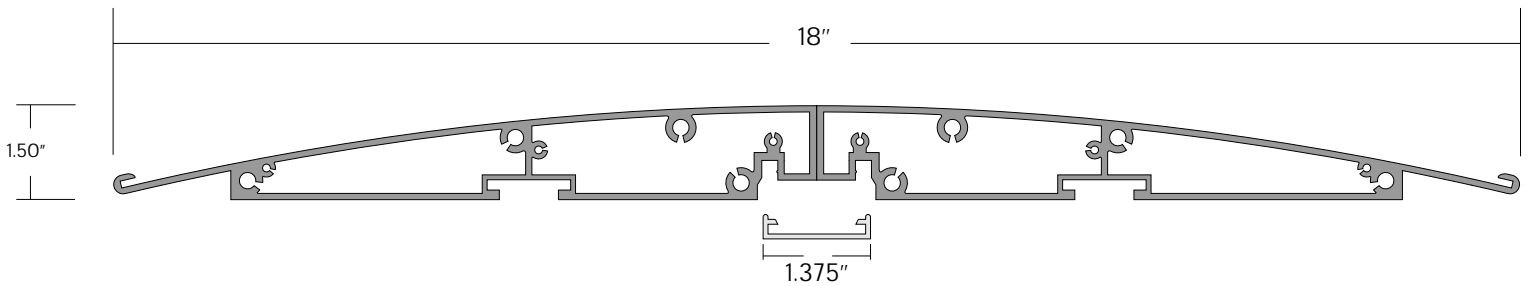

**F** **Width 18.00"** **NTS**

<b>Height:</b>	<b>8.86 - 11.75"</b>
	<b>9.1 - 18.00"</b>
	<b>10.1 - 10.00"</b>
	<b>11.1 - 15.875"</b>
	<b>12.1 - 21.75"</b>
	<b>13.1 - 27.625"</b>
	<b>14.0 - 15.625"</b>
	<b>15.0 - 25.00"</b>
	<b>16.0 - 34.375"</b>

### Interior

This drawing and the ideas expressed remain the confidential property of INNERFACE. This drawing and its ideas are not to be reproduced, copied, or disclosed to any other person or entity without the express written consent of a representative or agent of INNERFACE.



G

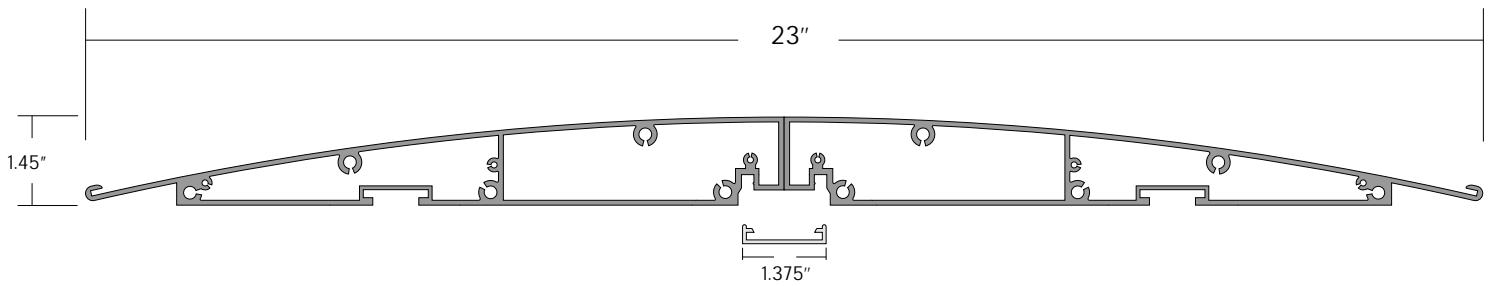

**Width 23.00"**

NTS

**Height:** 7.24 - 7.00"  
14.1 - 15.625"  
15.1 - 25.00"  
16.1 - 34.375"

### Interior

This drawing and the ideas expressed remain the confidential property of INNERFACE. This drawing and its ideas are not to be reproduced, copied, or disclosed to any other person or entity without the express written consent of a representative or agent of INNERFACE.

## ARQ SIGN TYPE MODULES

# 1.0

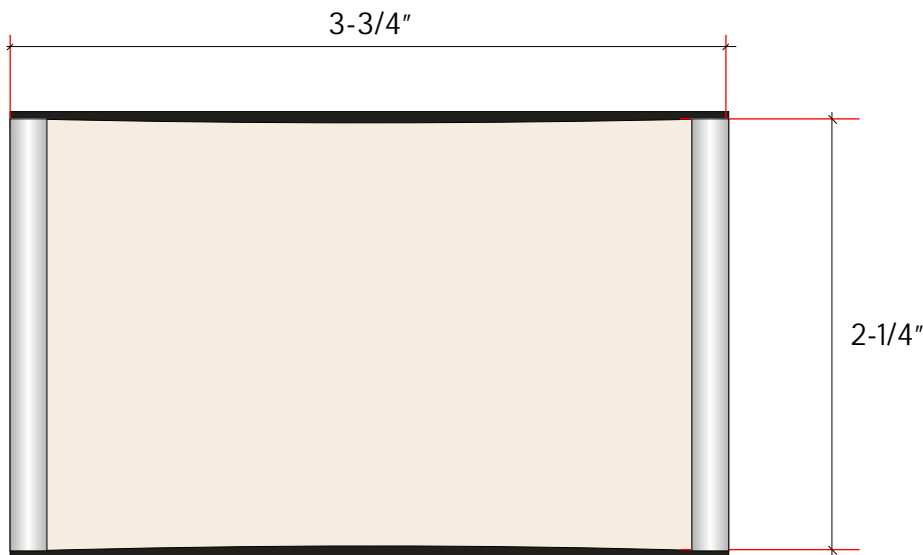
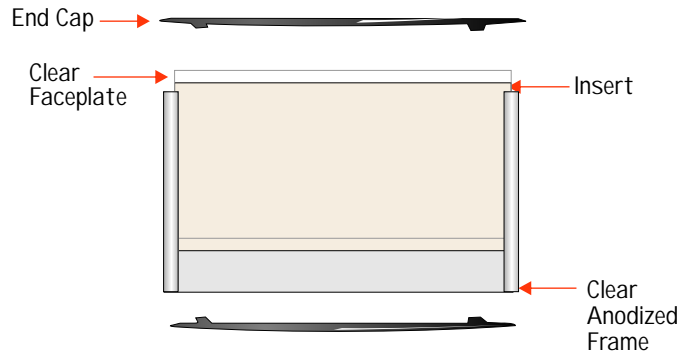

2-1/4" x 3-9/16" Insert Size

## Interior

This drawing and the ideas expressed remain the confidential property of INNERFACE. This drawing and its ideas are not to be reproduced, copied, or disclosed to any other person or entity without the express written consent of a representative or agent of INNERFACE.

## 2.0

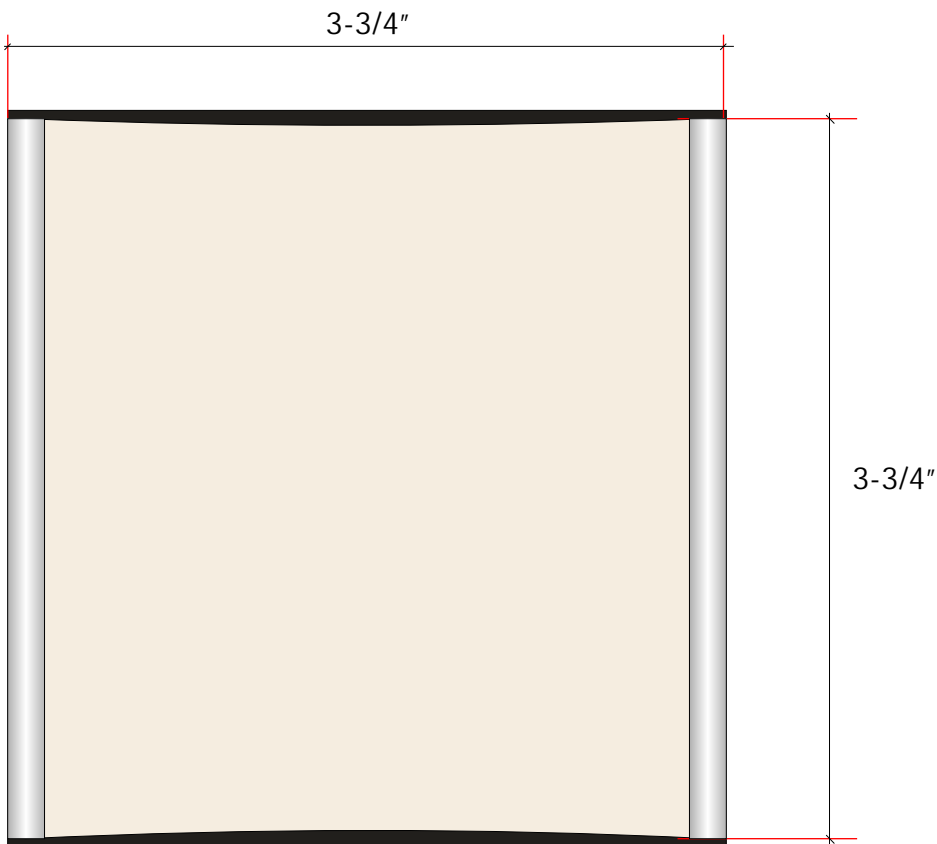
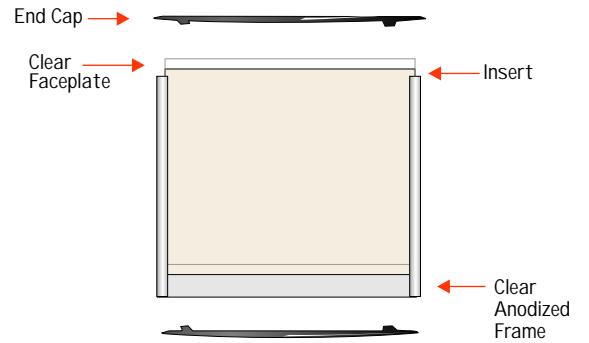

3-3/4" x 3-9/16" Insert Size

### Interior

This drawing and the ideas expressed remain the confidential property of INNERFACE. This drawing and its ideas are not to be reproduced, copied, or disclosed to any other person or entity without the express written consent of a representative or agent of INNERFACE.

## 2.11

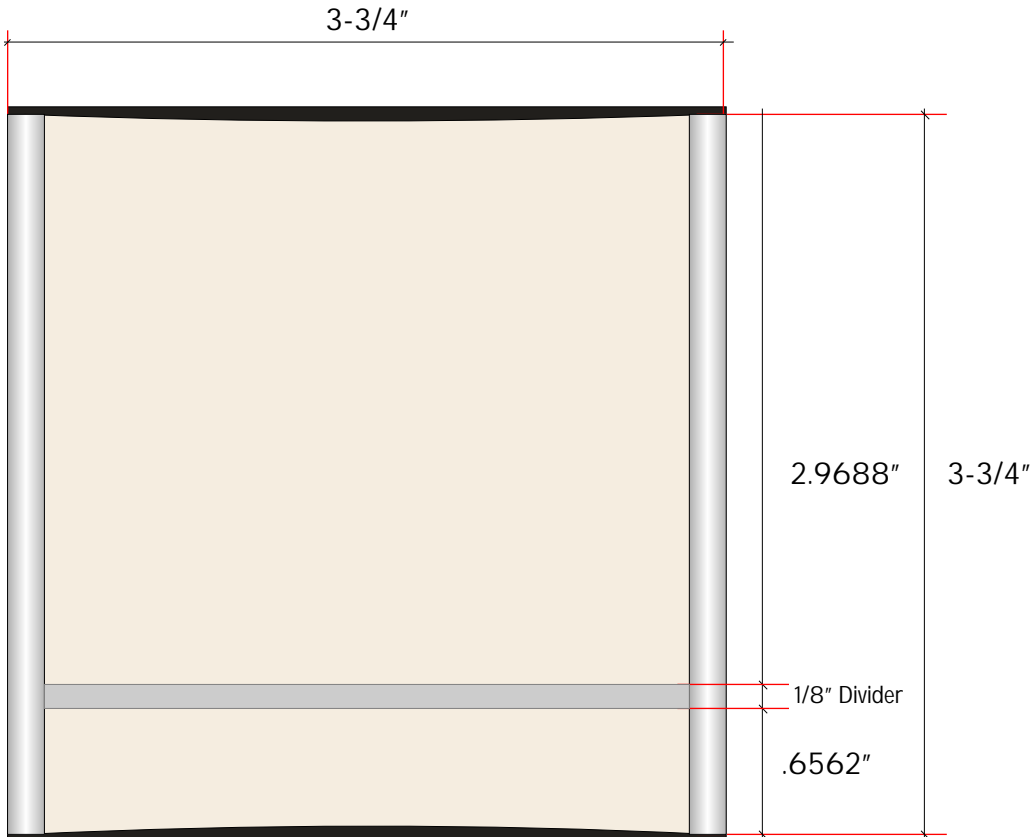
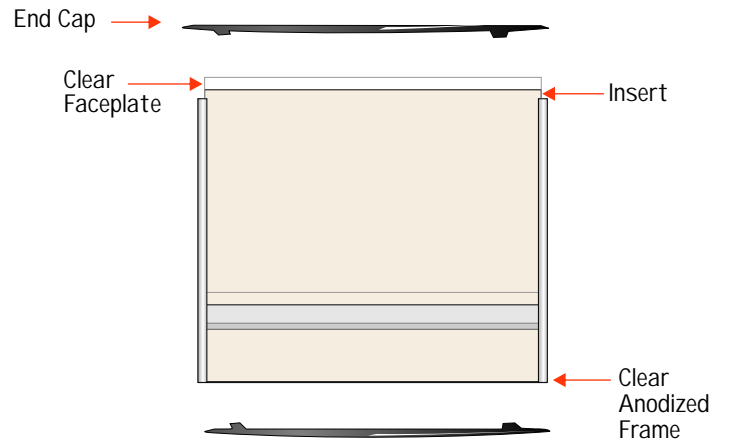

(1)A-Insert = 2.9688" x 3-9/16"

(1)B-Insert = .6562" x 3-9/16"

### Interior

This drawing and the ideas expressed remain the confidential property of INNERFACE. This drawing and its ideas are not to be reproduced, copied, or disclosed to any other person or entity without the express written consent of a representative or agent of INNERFACE.

## 2.22

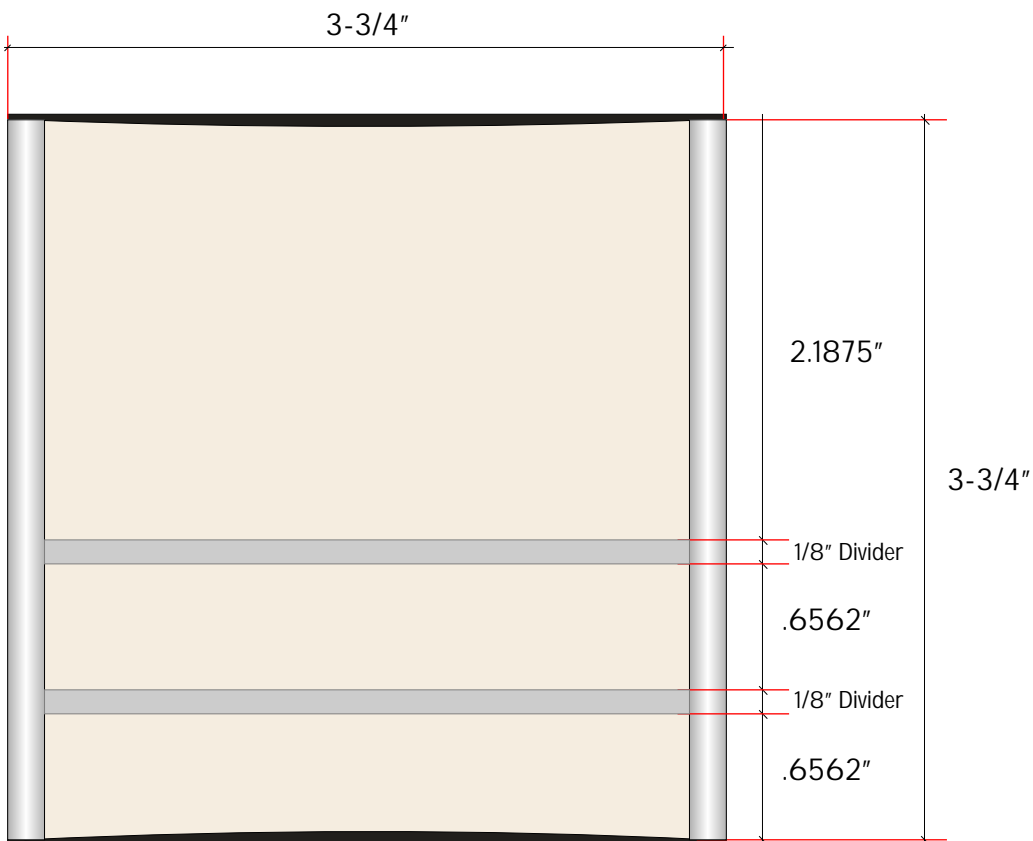
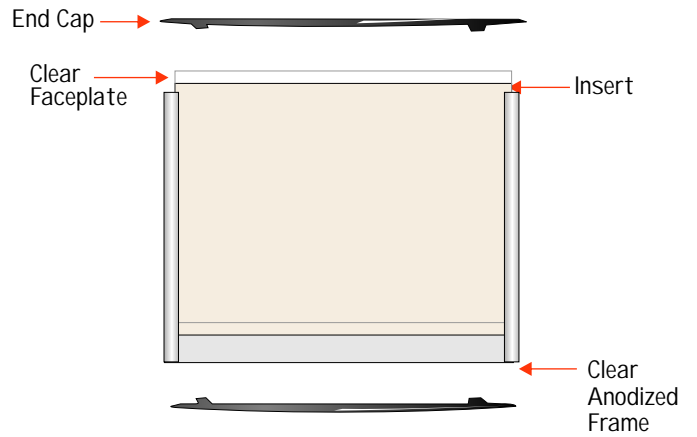

(1)A-Insert = 2.1875" x 3-9/16"

(2)B-Inserts = .6562" x 3-9/16"

### Interior

This drawing and the ideas expressed remain the confidential property of INNERFACE. This drawing and its ideas are not to be reproduced, copied, or disclosed to any other person or entity without the express written consent of a representative or agent of INNERFACE.

# 3.0

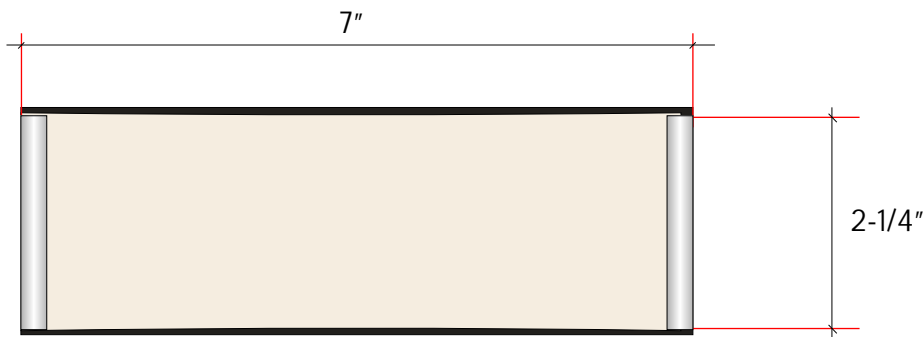
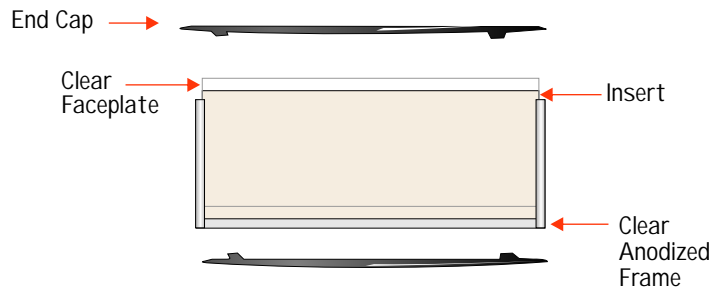

2-1/4" x 6-7/8" Insert Size

## Interior

This drawing and the ideas expressed remain the confidential property of INNERFACE. This drawing and its ideas are not to be reproduced, copied, or disclosed to any other person or entity without the express written consent of a representative or agent of INNERFACE.

### 3.7

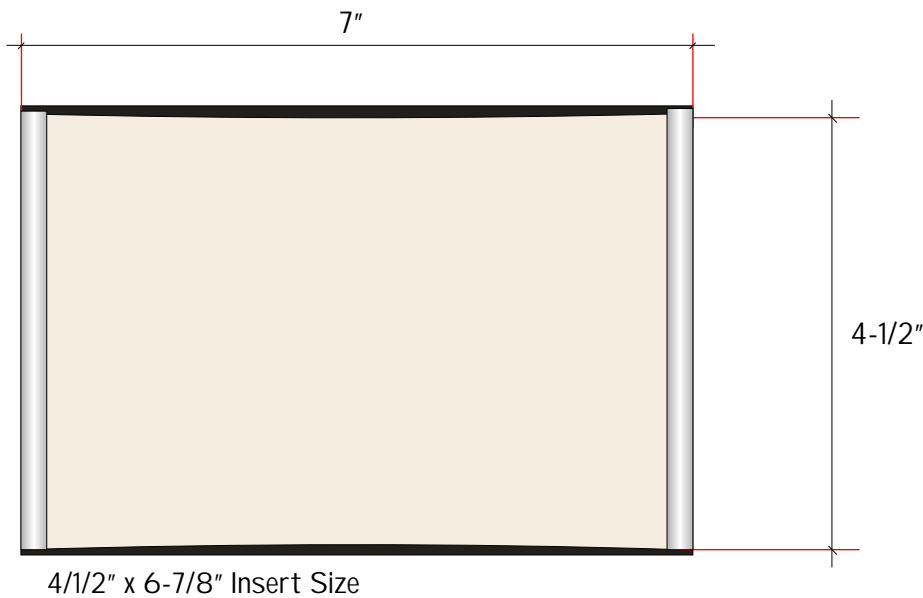
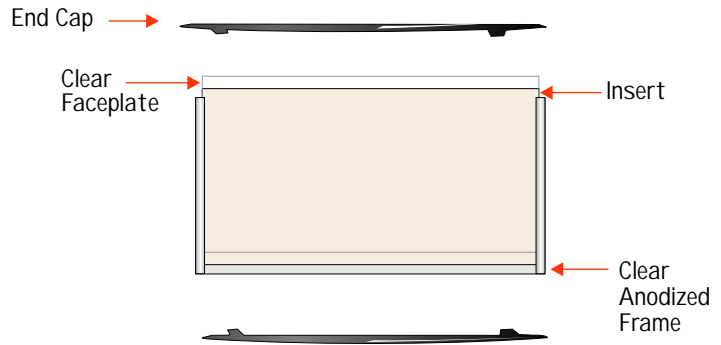

#### Interior

This drawing and the ideas expressed remain the confidential property of INNERFACE. This drawing and its ideas are not to be reproduced, copied, or disclosed to any other person or entity without the express written consent of a representative or agent of INNERFACE.



# 4.0

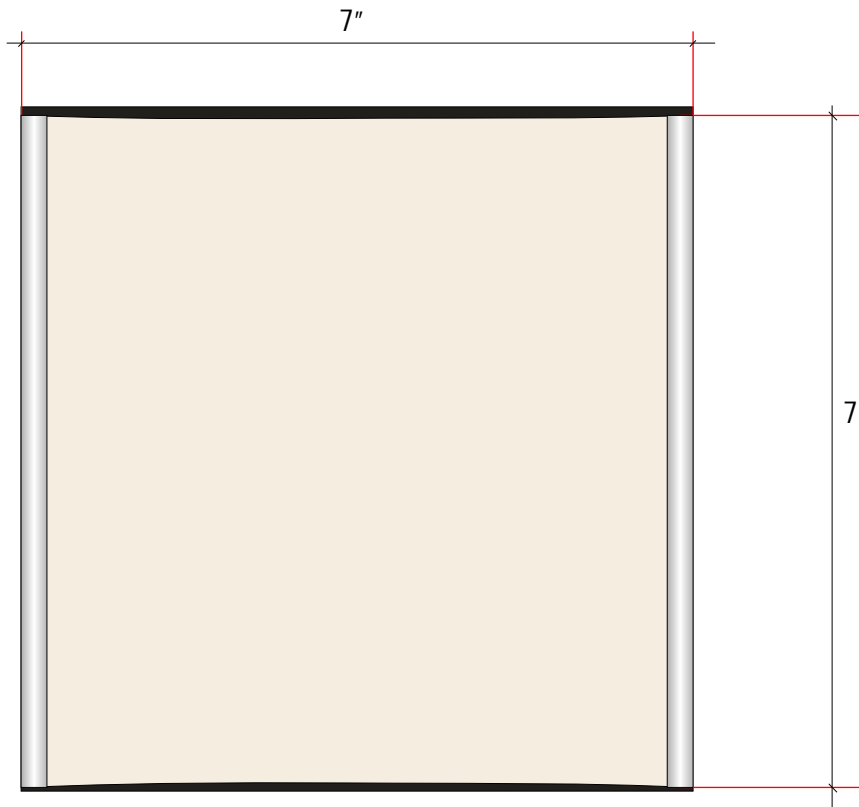
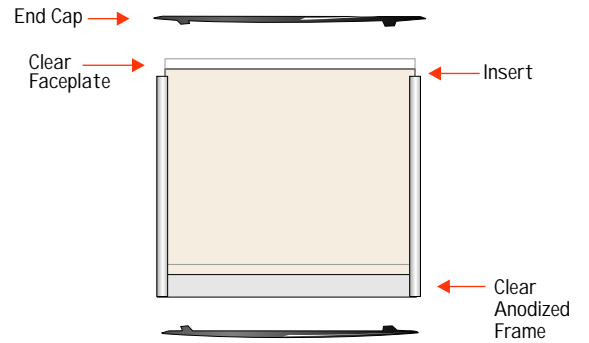

7" x 6-7/8" Insert Size

## Interior

This drawing and the ideas expressed remain the confidential property of INNERFACE. This drawing and its ideas are not to be reproduced, copied, or disclosed to any other person or entity without the express written consent of a representative or agent of INNERFACE.

# 4.11

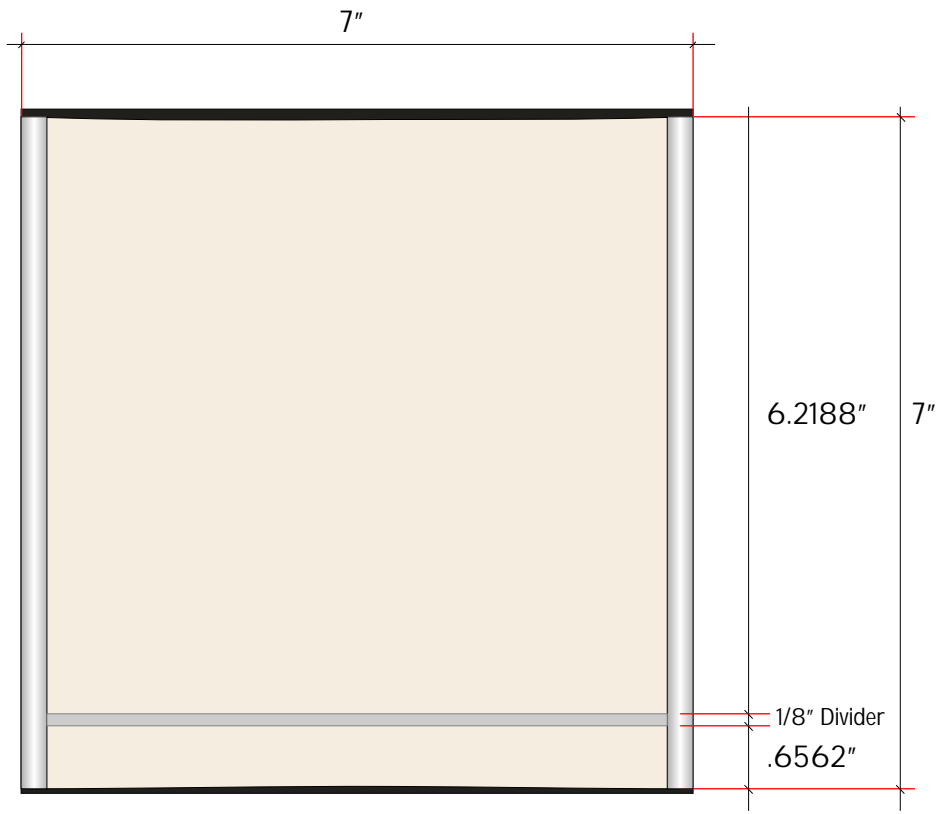
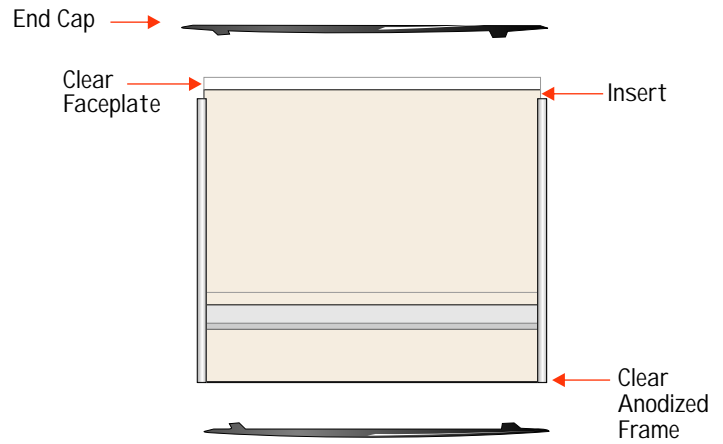

- (1)A-Insert = 6.2188" x 6-7/8"
- (1)B-Insert = .6562" x 6-7/8"

## Interior

This drawing and the ideas expressed remain the confidential property of INNERFACE. This drawing and its ideas are not to be reproduced, copied, or disclosed to any other person or entity without the express written consent of a representative or agent of INNERFACE.

## 4.22

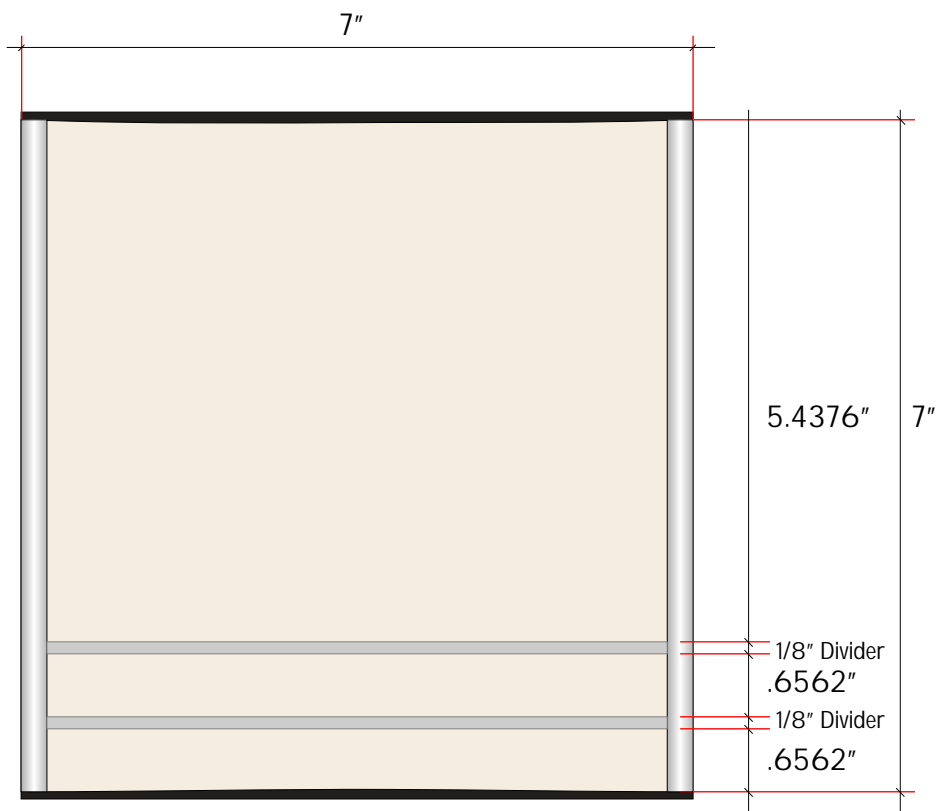
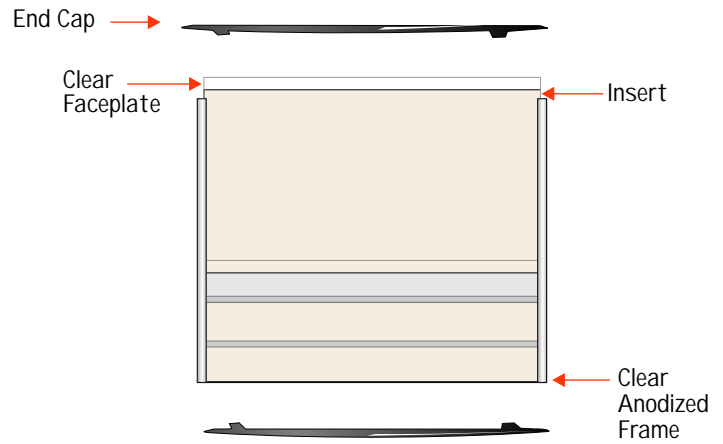

(1)A-Insert = 5.4376" x 6-7/8"

(2)B-Inserts = .6562" x 6-7/8"

### Interior

This drawing and the ideas expressed remain the confidential property of INNERFACE. This drawing and its ideas are not to be reproduced, copied, or disclosed to any other person or entity without the express written consent of a representative or agent of INNERFACE.

# 4.33

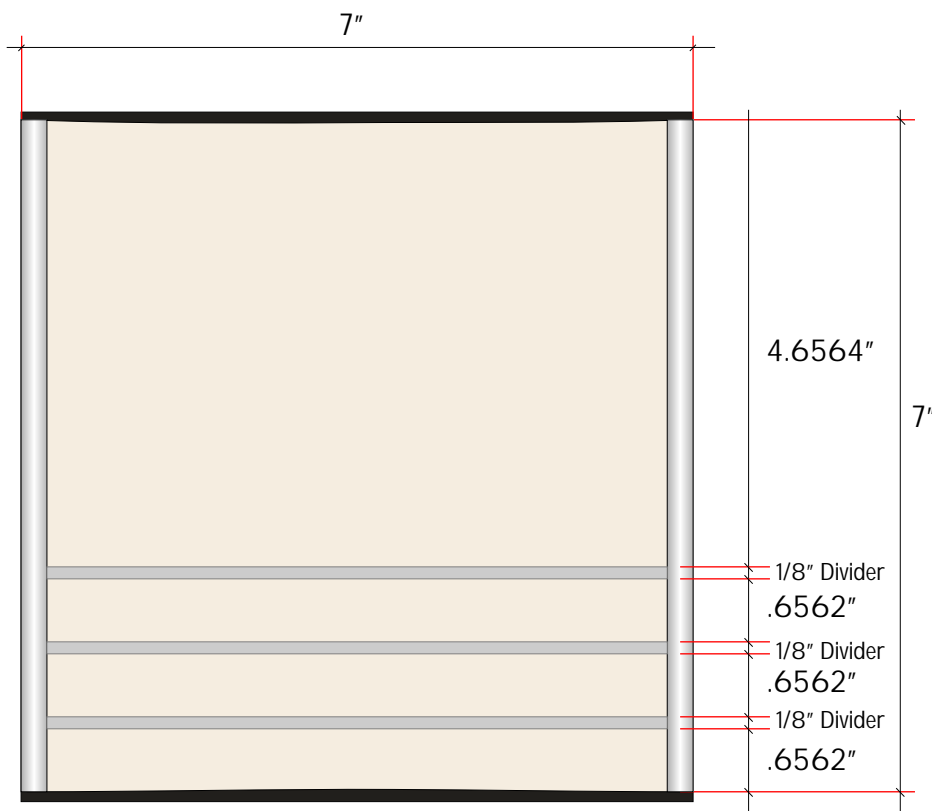
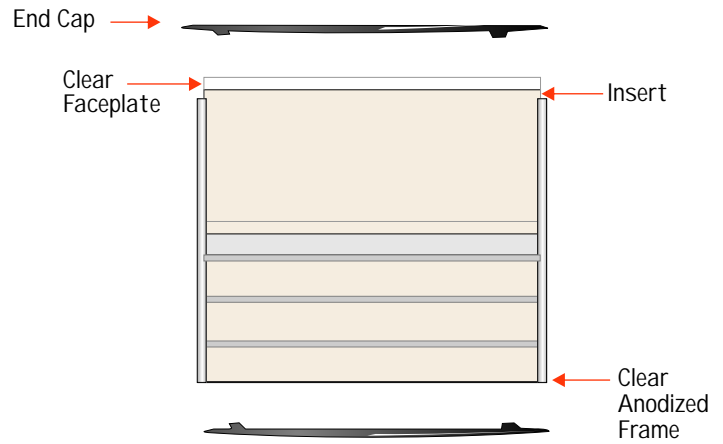

(1)A-Insert = 4.6564" x 6-7/8"

(3)B-Inserts = .6562" x 6-7/8"

## Interior

This drawing and the ideas expressed remain the confidential property of INNERFACE. This drawing and its ideas are not to be reproduced, copied, or disclosed to any other person or entity without the express written consent of a representative or agent of INNERFACE.

# 4.44

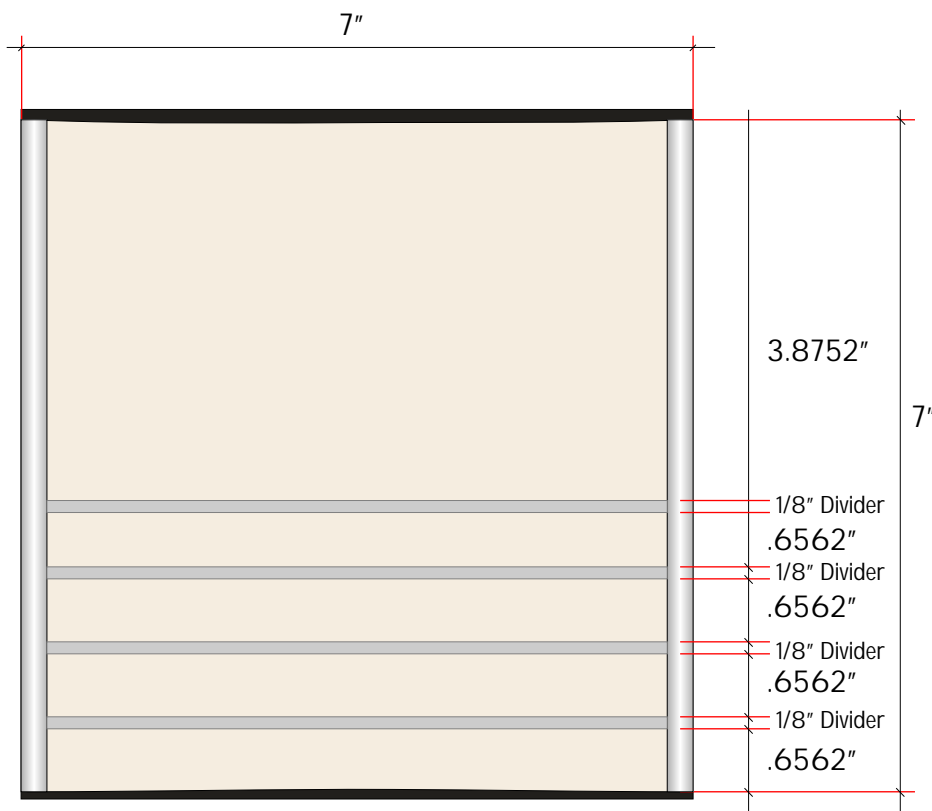
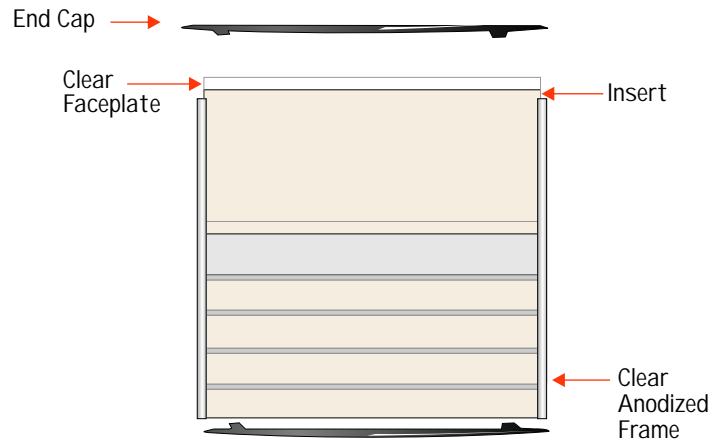

(1)A-Insert = 3.8752" x 6-7/8"

(4)B-Inserts = .6562" x 6-7/8"

## Interior

This drawing and the ideas expressed remain the confidential property of INNERFACE. This drawing and its ideas are not to be reproduced, copied, or disclosed to any other person or entity without the express written consent of a representative or agent of INNERFACE.

## 4.6

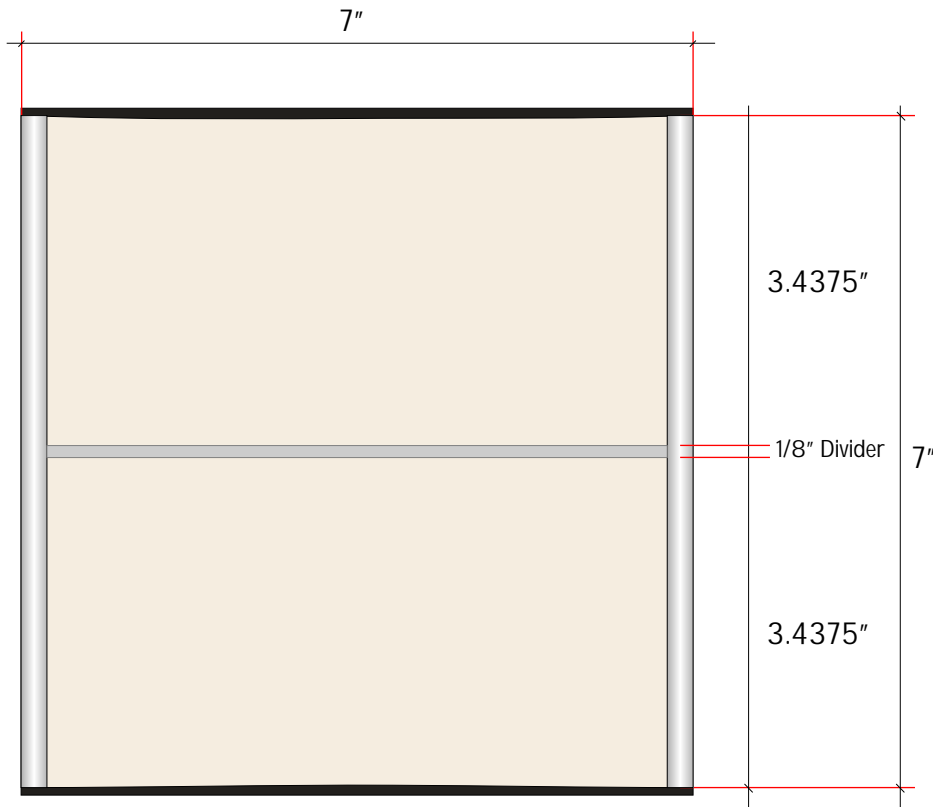
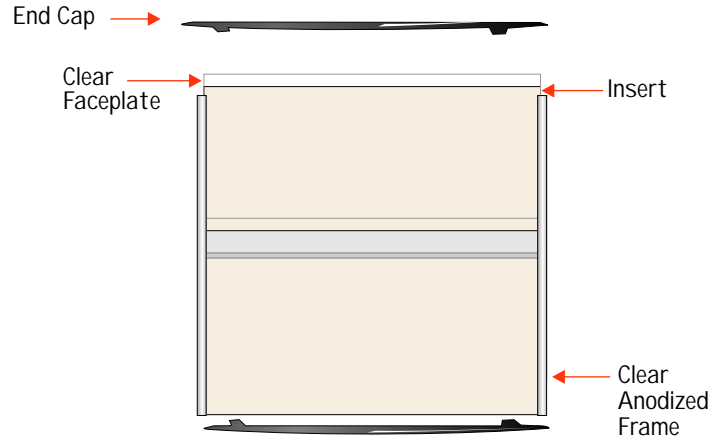

(2) Inserts = 3.4375" x 6-7/8"

### Interior

This drawing and the ideas expressed remain the confidential property of INNERFACE. This drawing and its ideas are not to be reproduced, copied, or disclosed to any other person or entity without the express written consent of a representative or agent of INNERFACE.

# 4.7

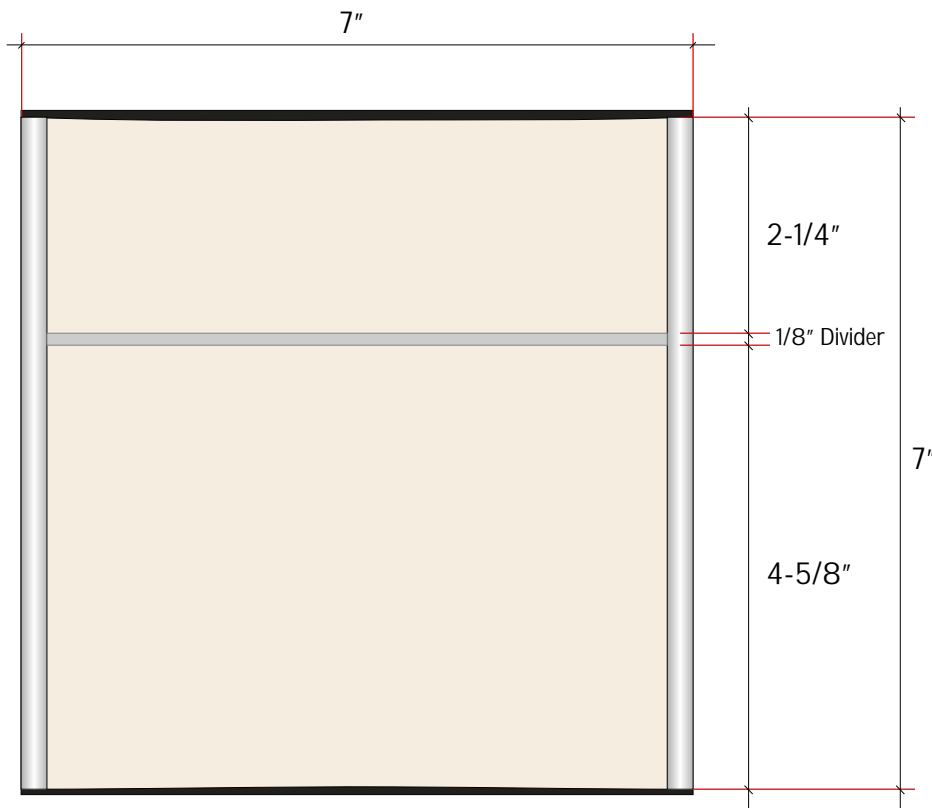
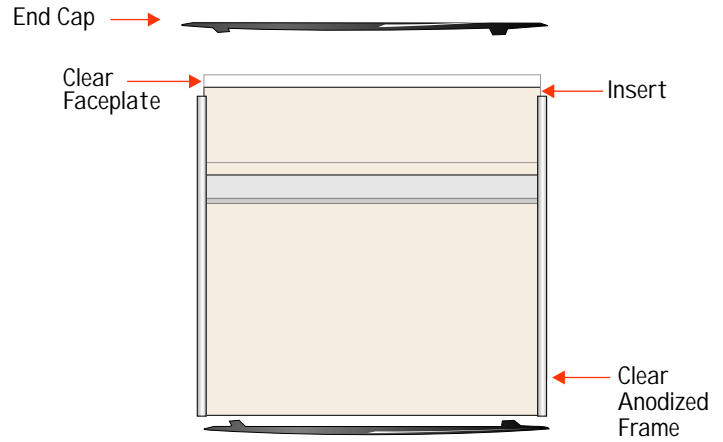

- (1)A-Insert = 2-1/4" x 6-7/8"
- (1)B-Insert = 4-5/8" x 6-7/8"

## Interior

This drawing and the ideas expressed remain the confidential property of INNERFACE. This drawing and its ideas are not to be reproduced, copied, or disclosed to any other person or entity without the express written consent of a representative or agent of INNERFACE.

# 5.0

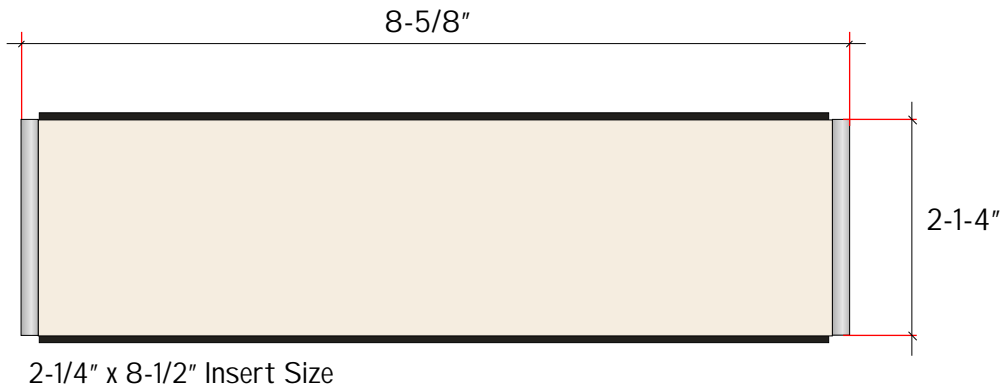
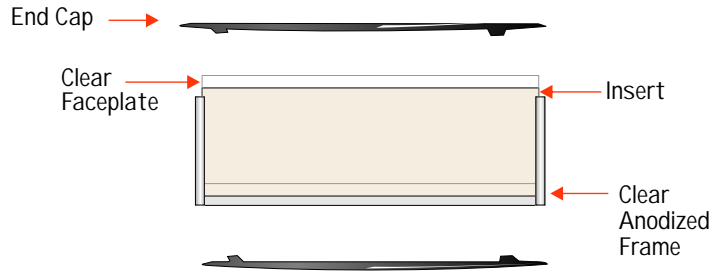

## Interior

This drawing and the ideas expressed remain the confidential property of INNERFACE. This drawing and its ideas are not to be reproduced, copied, or disclosed to any other person or entity without the express written consent of a representative or agent of INNERFACE.



# 5.5

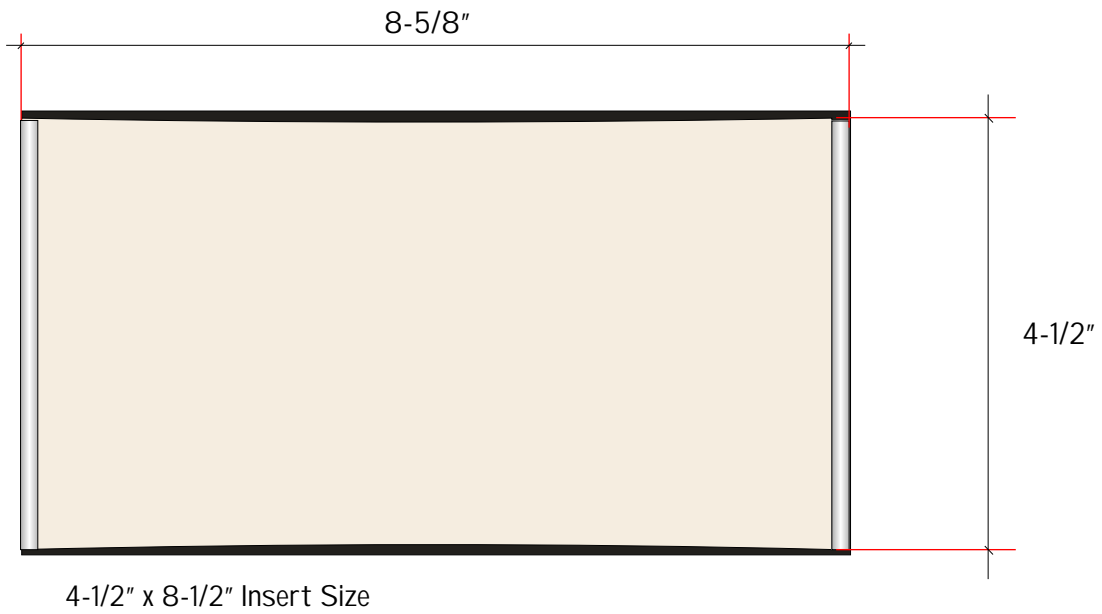
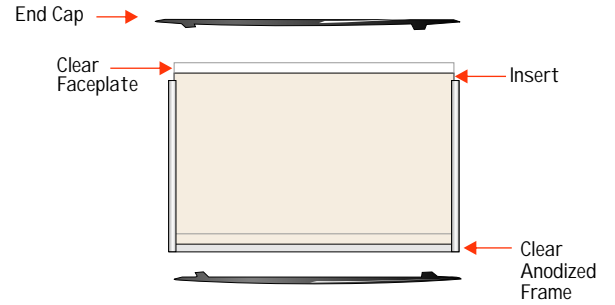

## Interior

This drawing and the ideas expressed remain the confidential property of INNERFACE. This drawing and its ideas are not to be reproduced, copied, or disclosed to any other person or entity without the express written consent of a representative or agent of INNERFACE.

# 5.6

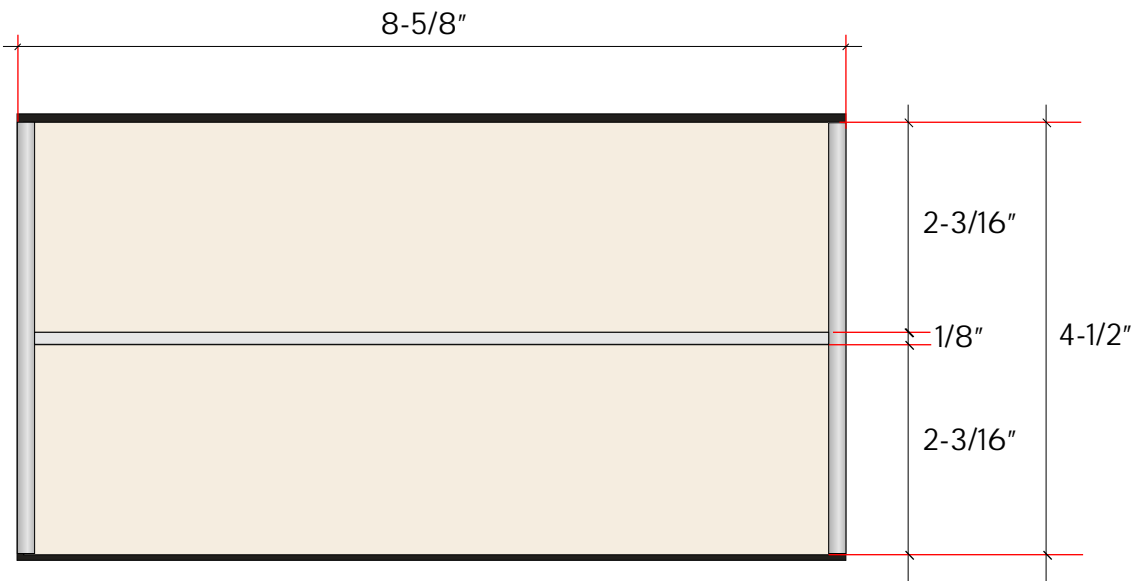
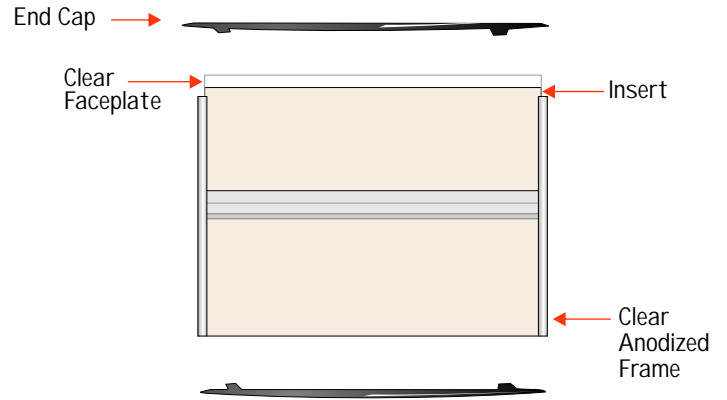

(2) Inserts =  $2\frac{3}{16}$ " x  $8\frac{1}{2}$ "

## Interior

This drawing and the ideas expressed remain the confidential property of INNERFACE. This drawing and its ideas are not to be reproduced, copied, or disclosed to any other person or entity without the express written consent of a representative or agent of INNERFACE.

# 6.0

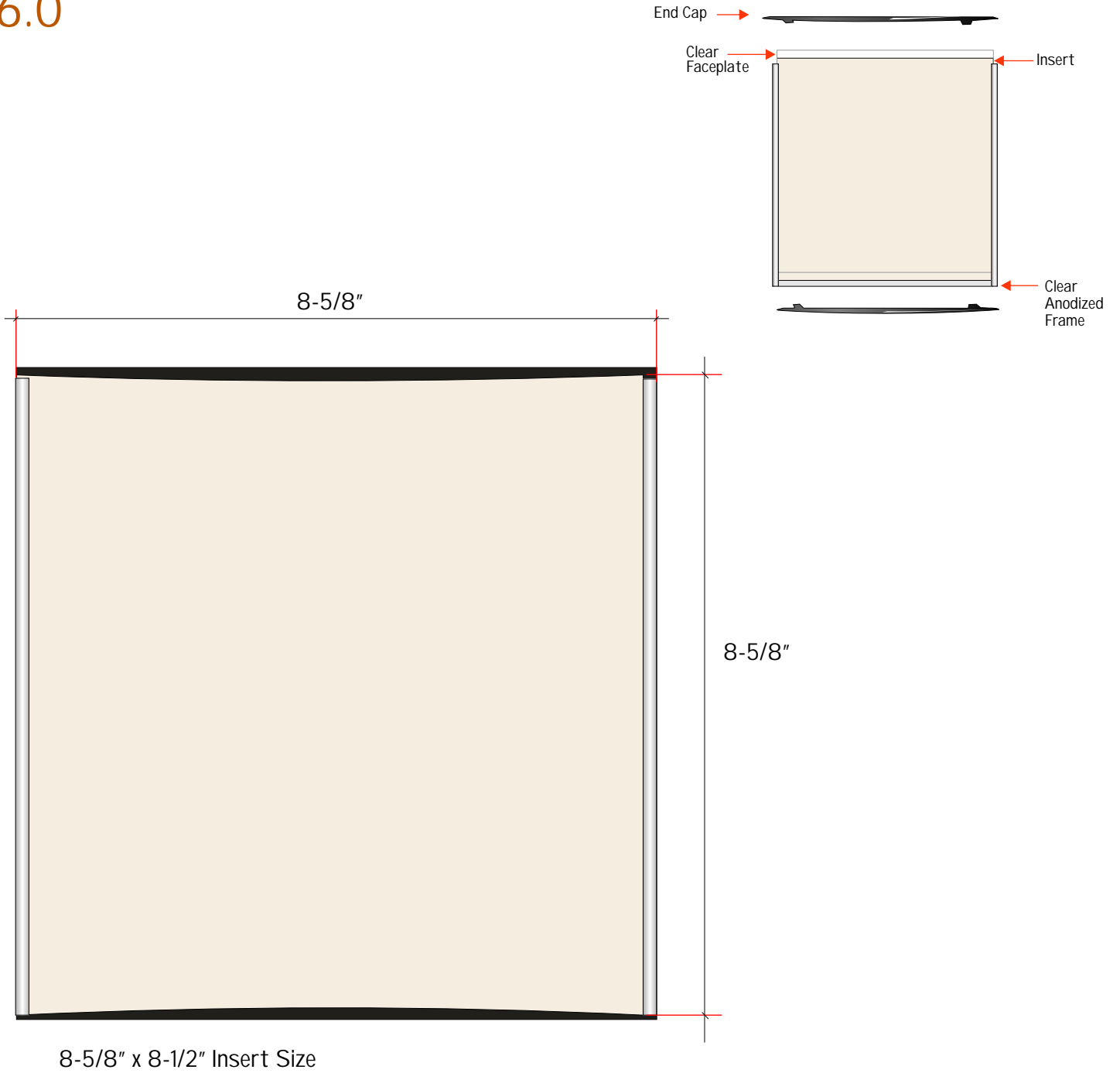

## Interior

This drawing and the ideas expressed remain the confidential property of INNERFACE. This drawing and its ideas are not to be reproduced, copied, or disclosed to any other person or entity without the express written consent of a representative or agent of INNERFACE.

# 6.11

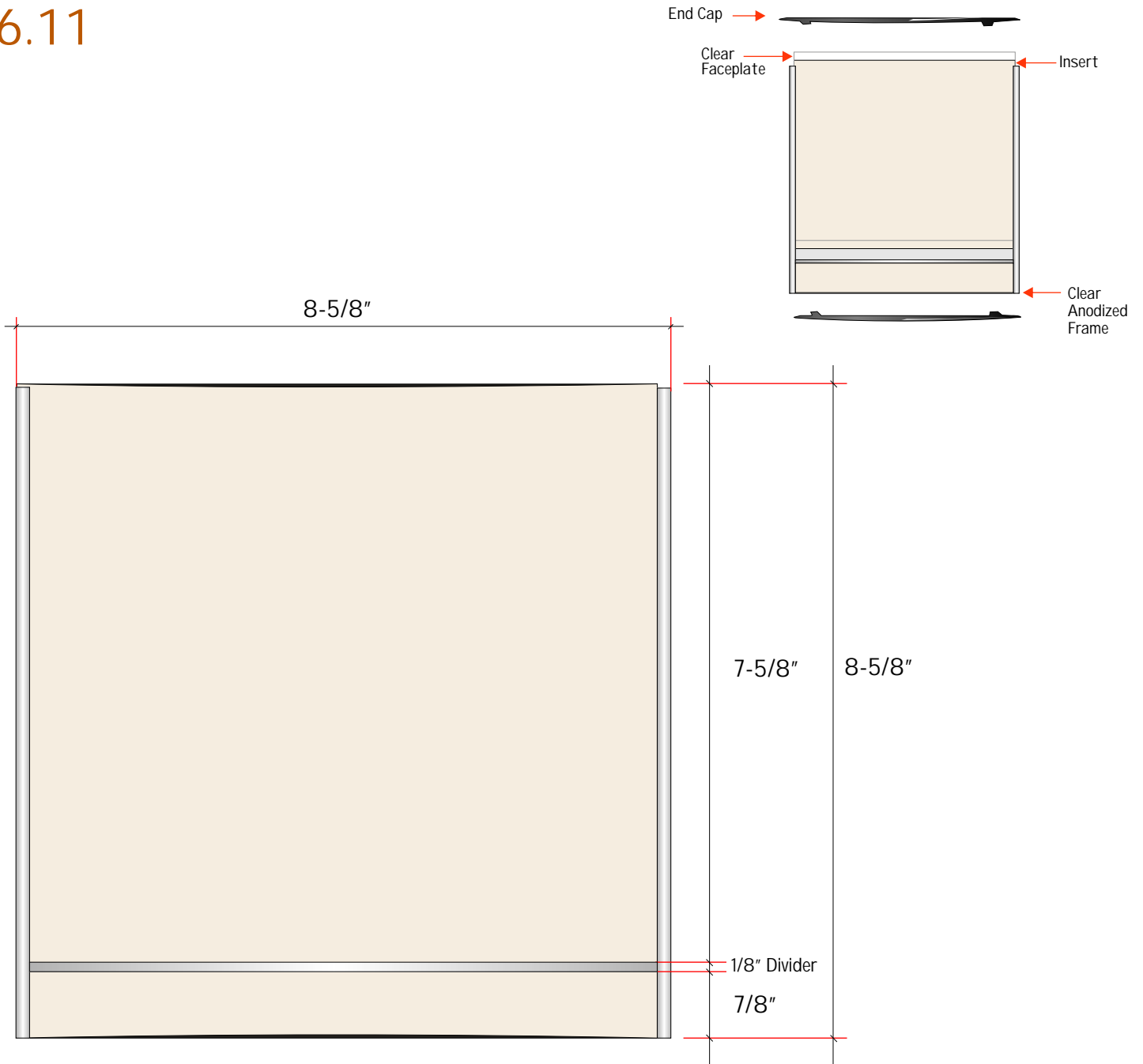

(1)A Insert = 7-5/8" x 8-1/2"

(1)B Insert = 7/8" x 8-1/2"

## Interior

This drawing and the ideas expressed remain the confidential property of INNERFACE. This drawing and its ideas are not to be reproduced, copied, or disclosed to any other person or entity without the express written consent of a representative or agent of INNERFACE.

# 6.22

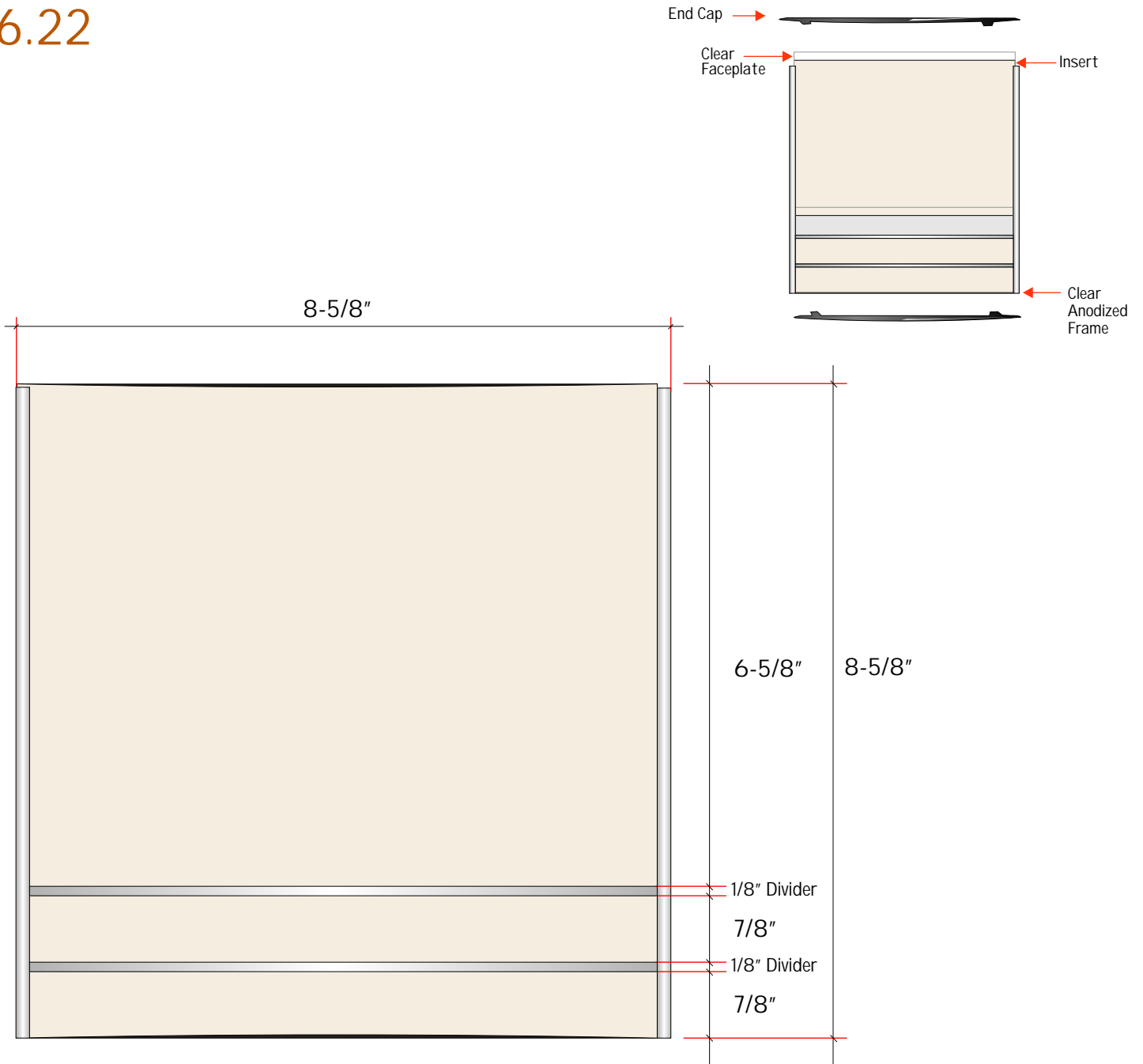

(1)A Insert = 6-5/8" x 8-1/2"

(2)B Inserts = 7/8" x 8-1/2"

## Interior

This drawing and the ideas expressed remain the confidential property of INNERFACE. This drawing and its ideas are not to be reproduced, copied, or disclosed to any other person or entity without the express written consent of a representative or agent of INNERFACE.

# 6.33

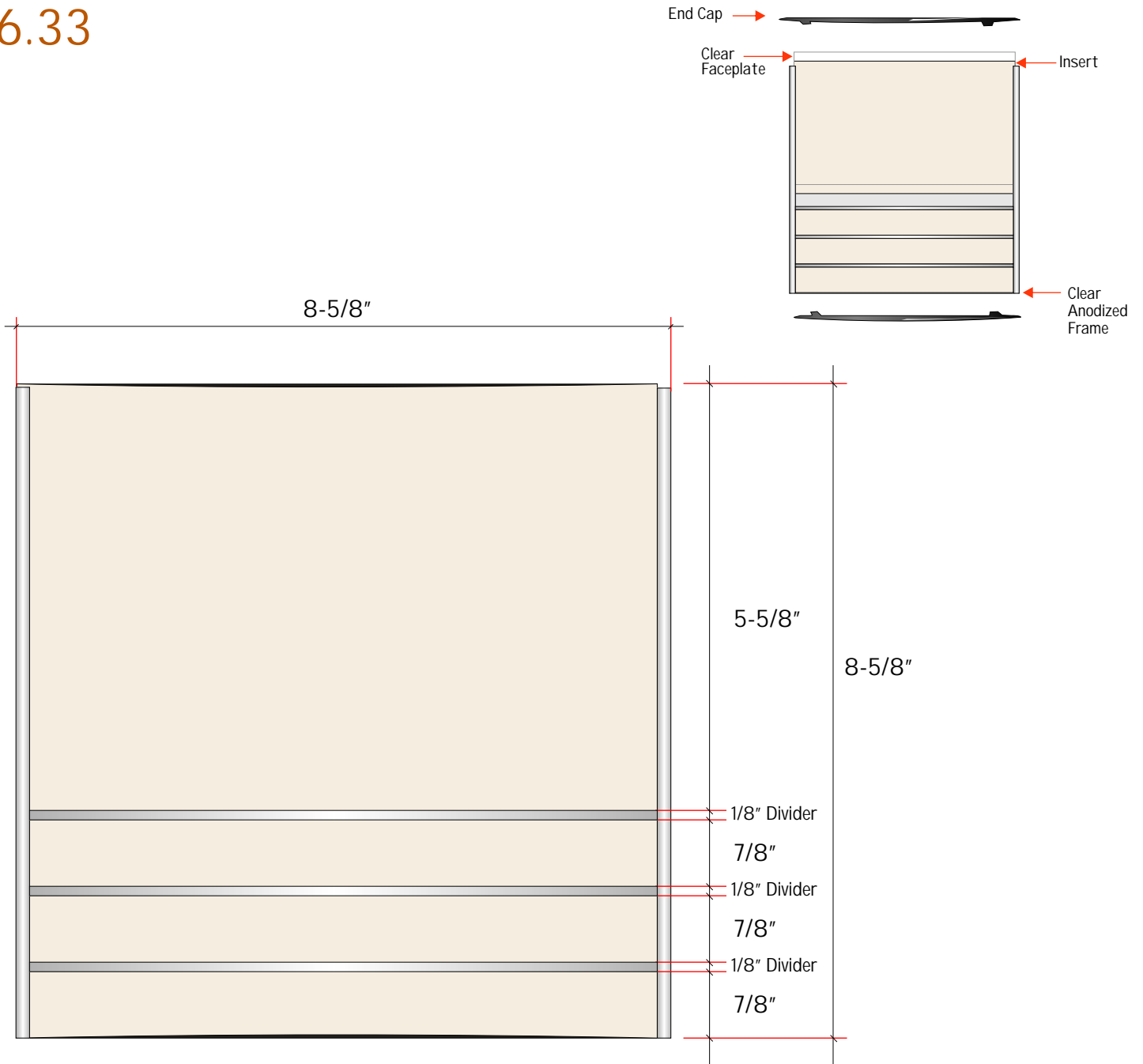

(1)A Insert = 5-5/8" x 8-1/2"

(3)B Inserts = 7/8" x 8-1/2"

## Interior

This drawing and the ideas expressed remain the confidential property of INNERFACE. This drawing and its ideas are not to be reproduced, copied, or disclosed to any other person or entity without the express written consent of a representative or agent of INNERFACE.

# 6.44

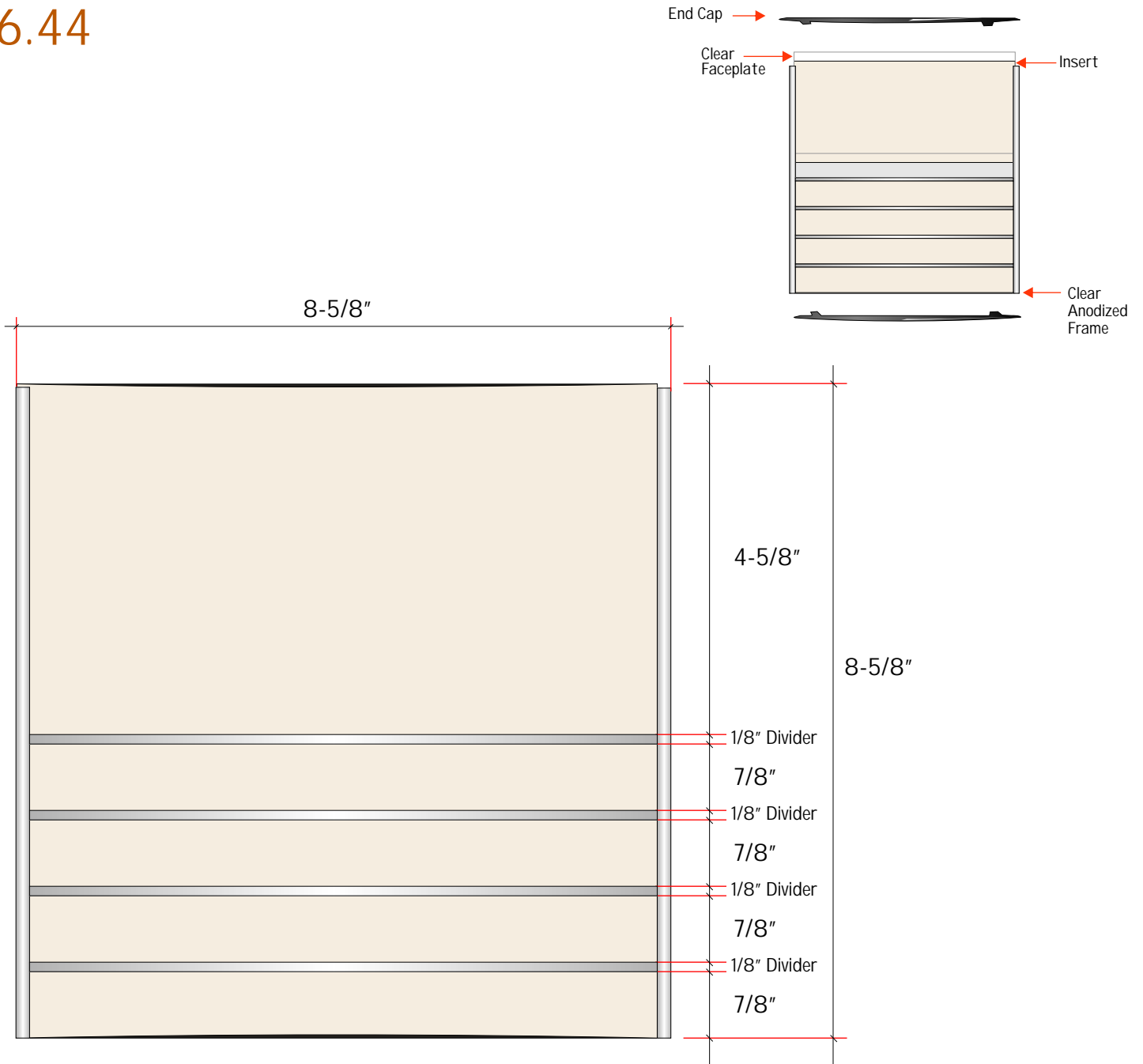

(1)A Insert = 4-5/8" x 8-1/2"

(4)B Inserts = 7/8" x 8-1/2"

## Interior

This drawing and the ideas expressed remain the confidential property of INNERFACE. This drawing and its ideas are not to be reproduced, copied, or disclosed to any other person or entity without the express written consent of a representative or agent of INNERFACE.

## 6.6

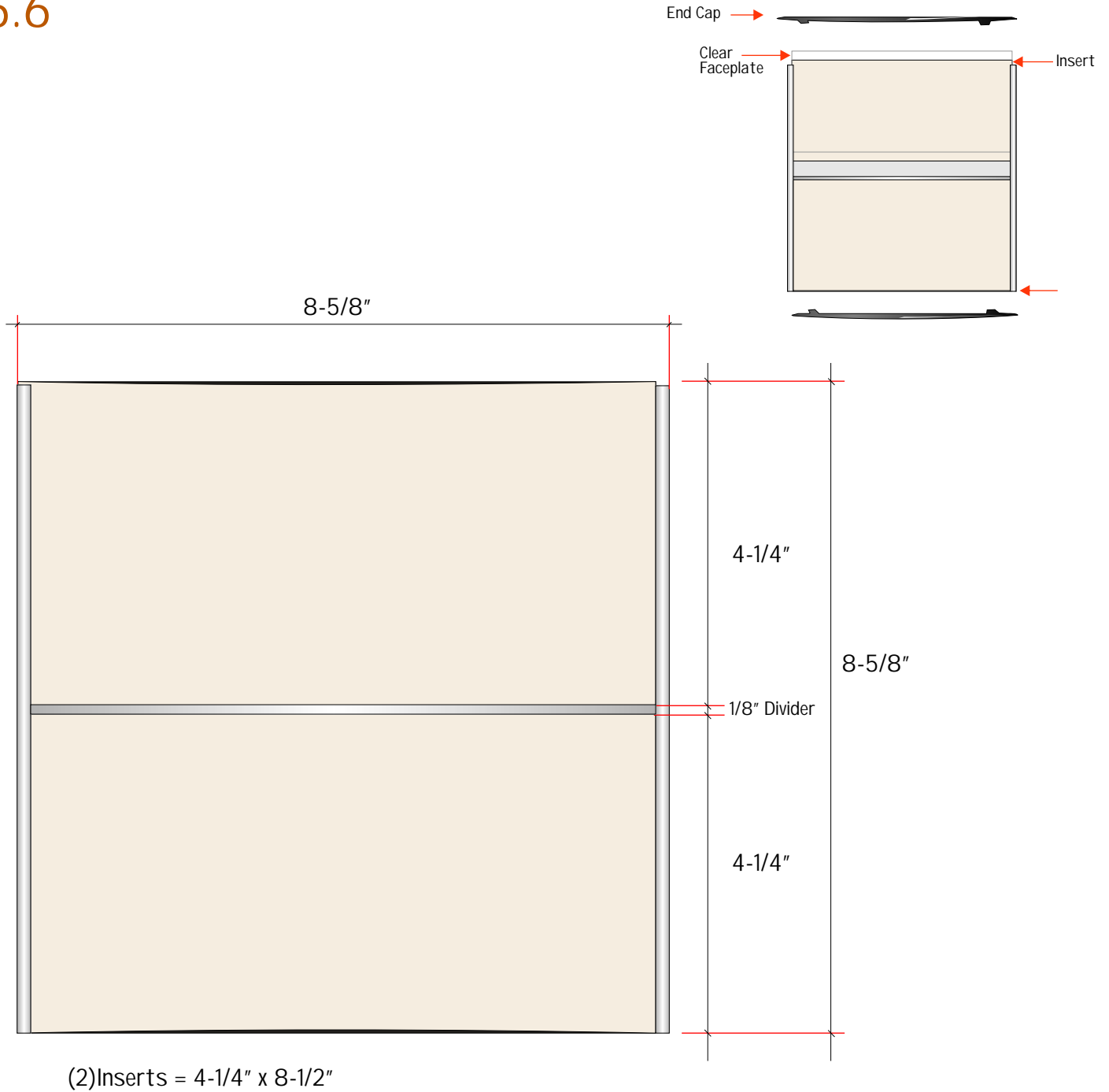

### Interior

This drawing and the ideas expressed remain the confidential property of INNERFACE. This drawing and its ideas are not to be reproduced, copied, or disclosed to any other person or entity without the express written consent of a representative or agent of INNERFACE.



# 7.0

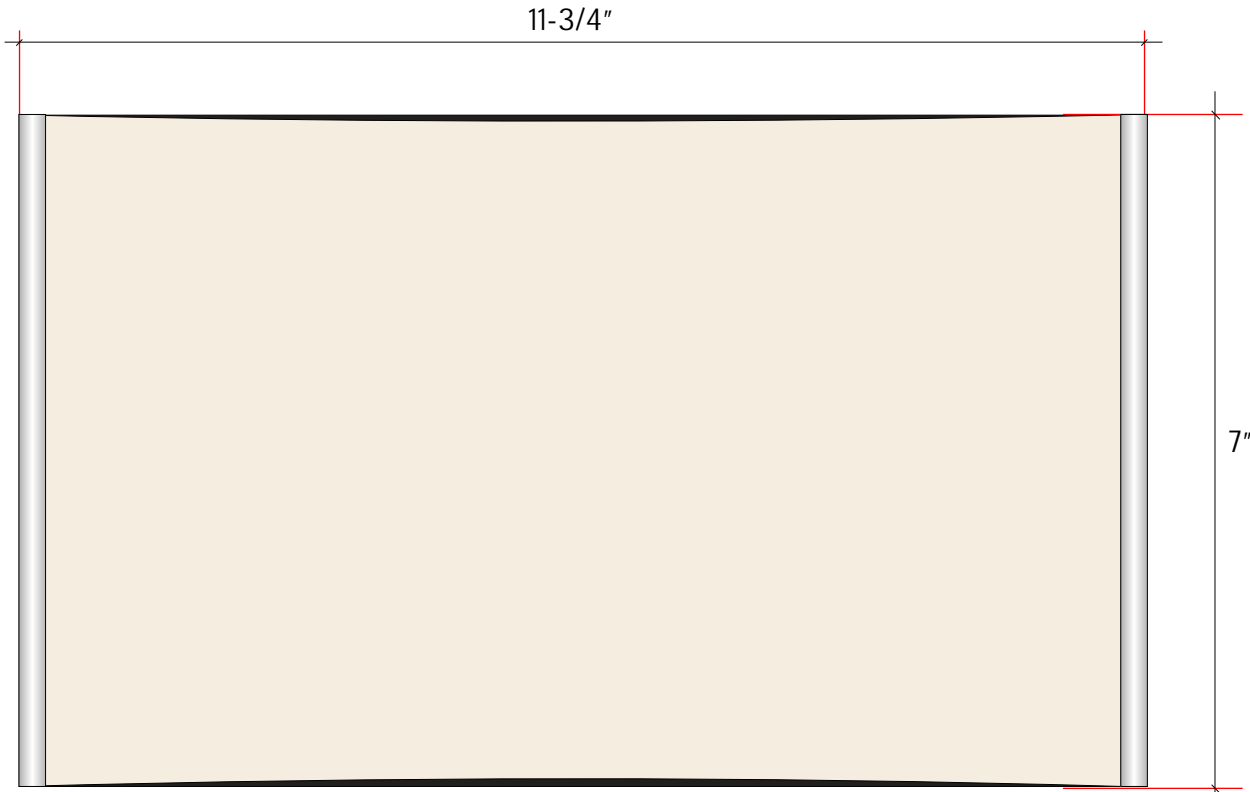
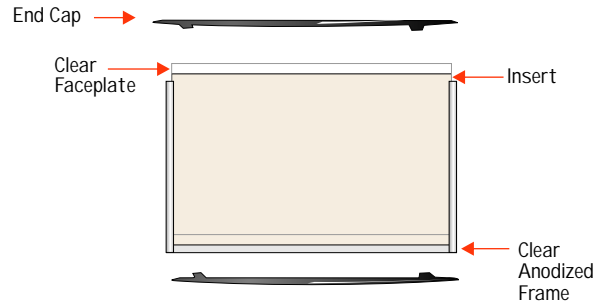

7" x 11-5/8" Insert Size

## Interior

This drawing and the ideas expressed remain the confidential property of INNERFACE. This drawing and its ideas are not to be reproduced, copied, or disclosed to any other person or entity without the express written consent of a representative or agent of INNERFACE.

# 7.0V

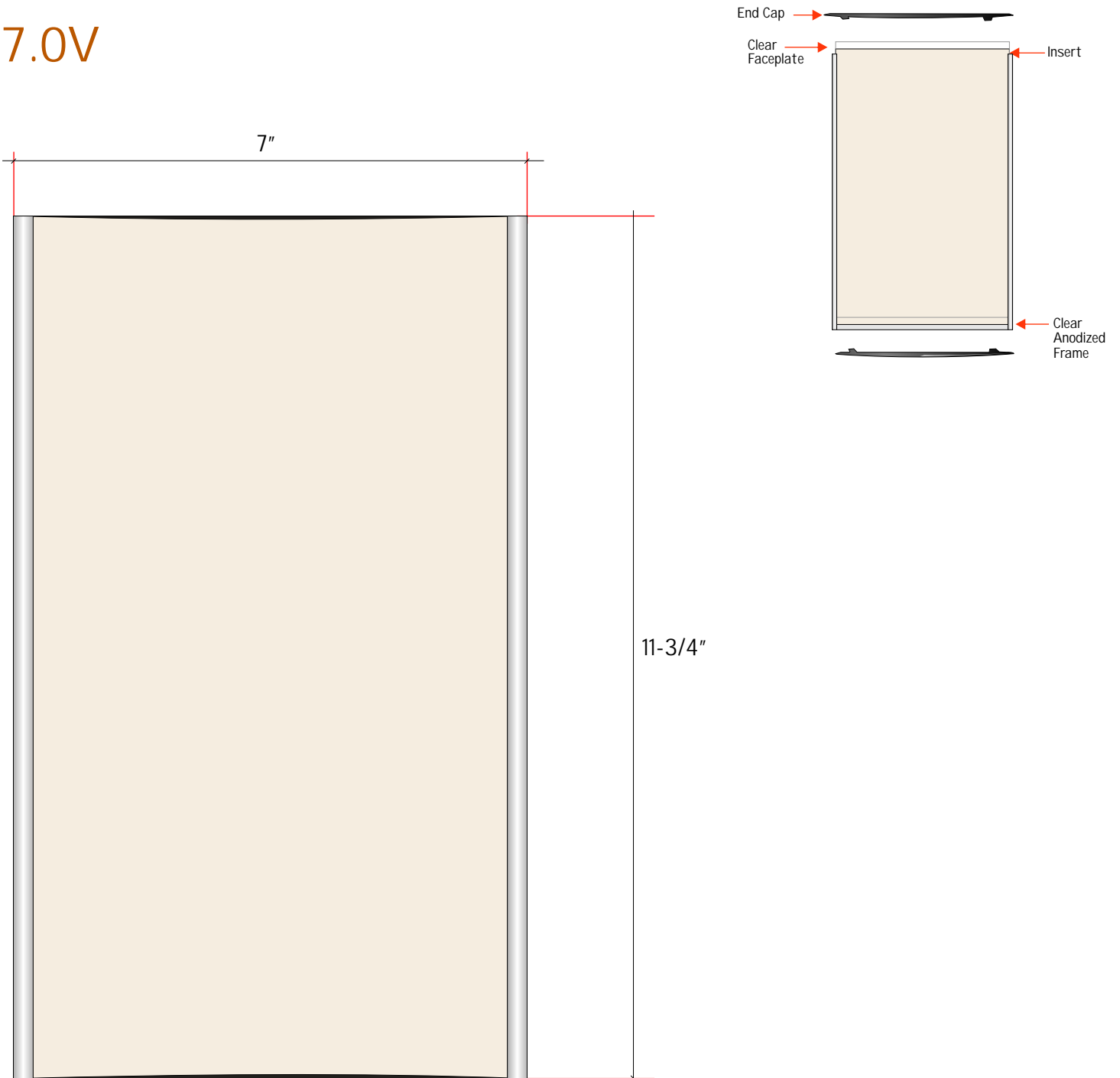

11-3/4" x 6-7/8" Insert Size

## Interior

This drawing and the ideas expressed remain the confidential property of INNERFACE. This drawing and its ideas are not to be reproduced, copied, or disclosed to any other person or entity without the express written consent of a representative or agent of INNERFACE.

# 7.1

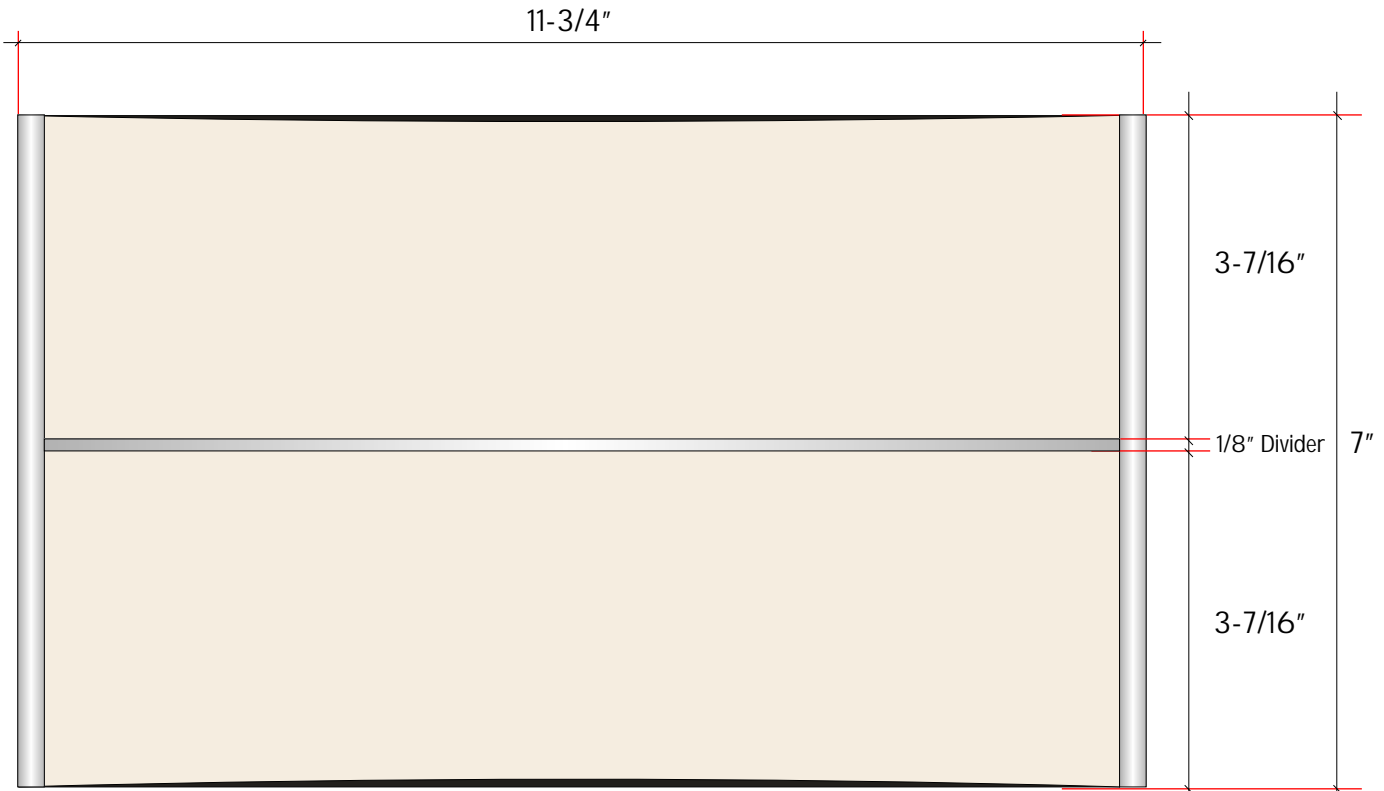
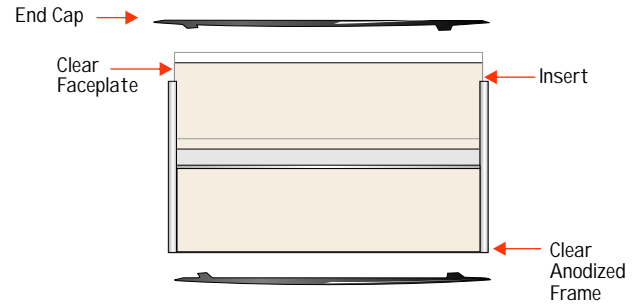

(2) Inserts = 3-7/16" x 11-5/8"

## Interior

This drawing and the ideas expressed remain the confidential property of INNERFACE. This drawing and its ideas are not to be reproduced, copied, or disclosed to any other person or entity without the express written consent of a representative or agent of INNERFACE.

# 7.24

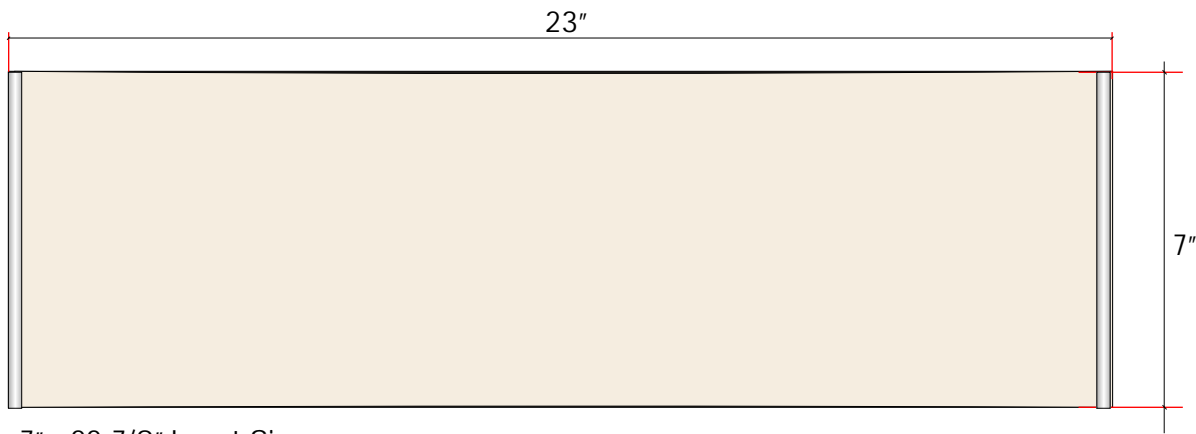
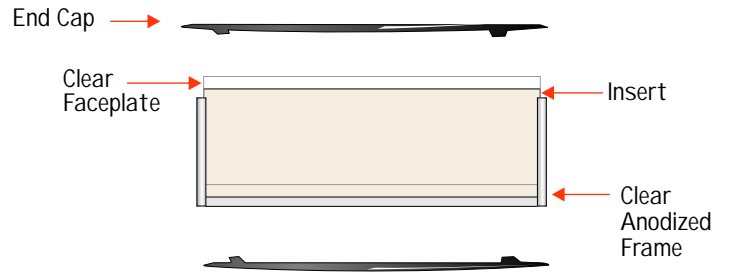

7" x 22-7/8" Insert Size

## Interior

This drawing and the ideas expressed remain the confidential property of INNERFACE. This drawing and its ideas are not to be reproduced, copied, or disclosed to any other person or entity without the express written consent of a representative or agent of INNERFACE.

# 8.0

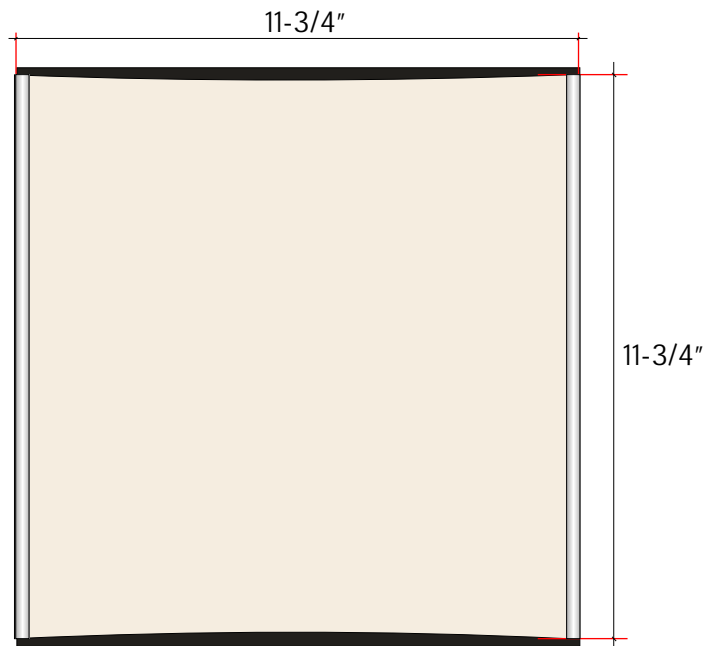

11-3/4" x 11-5/8" Insert Size

## Interior

This drawing and the ideas expressed remain the confidential property of INNERFACE. This drawing and its ideas are not to be reproduced, copied, or disclosed to any other person or entity without the express written consent of a representative or agent of INNERFACE.

# 8.11

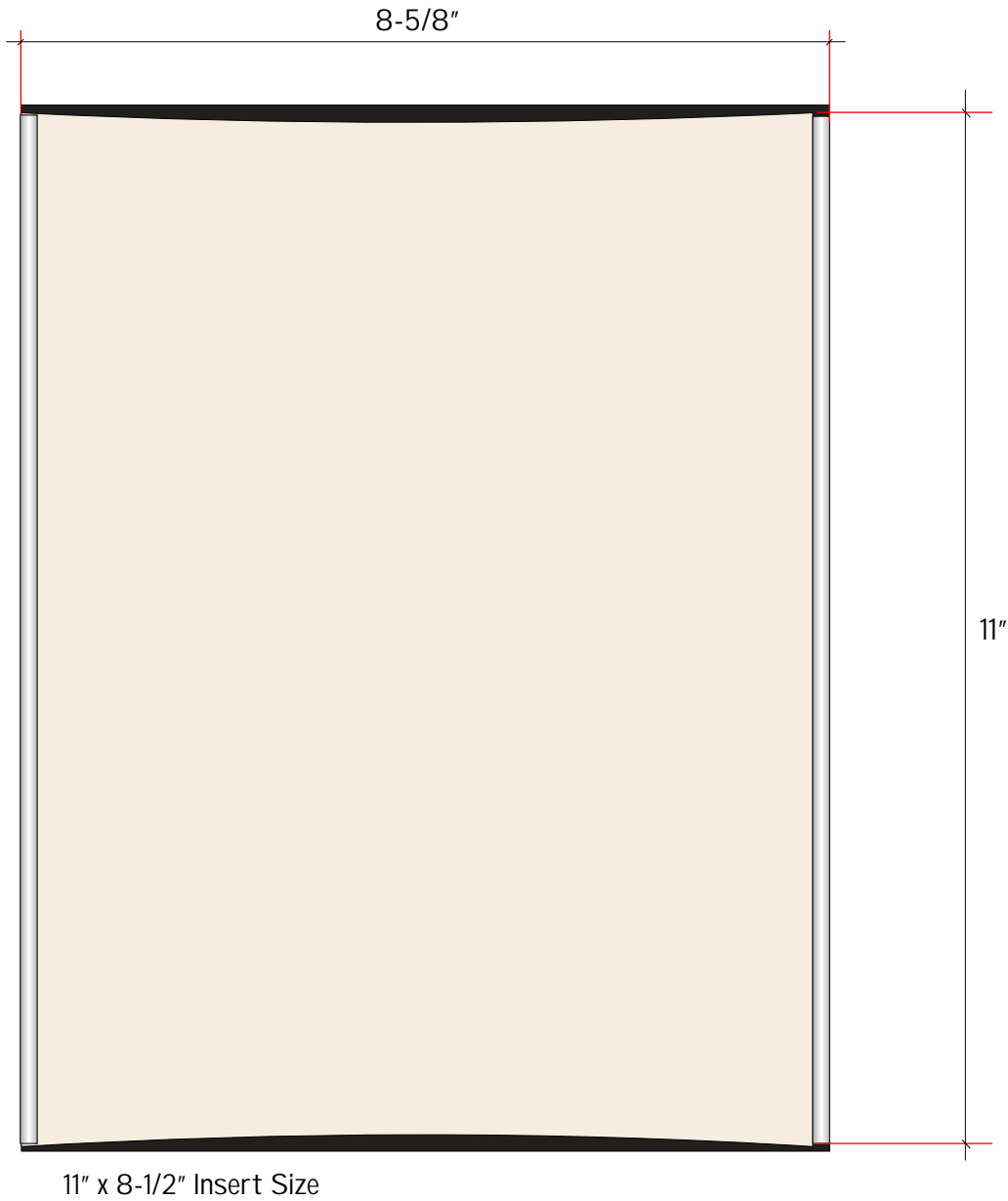

## Interior

This drawing and the ideas expressed remain the confidential property of INNERFACE. This drawing and its ideas are not to be reproduced, copied, or disclosed to any other person or entity without the express written consent of a representative or agent of INNERFACE.

## 8.12

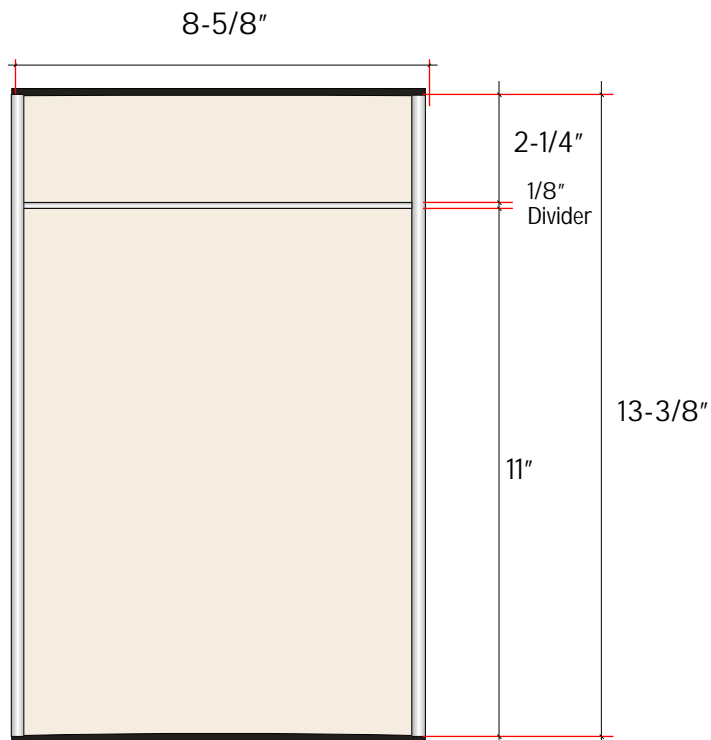

(1)A Insert = 2-1/4" x 8-1/2"  
(1)B Insert = 11" x 8-1/2"

### Interior

This drawing and the ideas expressed remain the confidential property of INNERFACE. This drawing and its ideas are not to be reproduced, copied, or disclosed to any other person or entity without the express written consent of a representative or agent of INNERFACE.

## 8.6

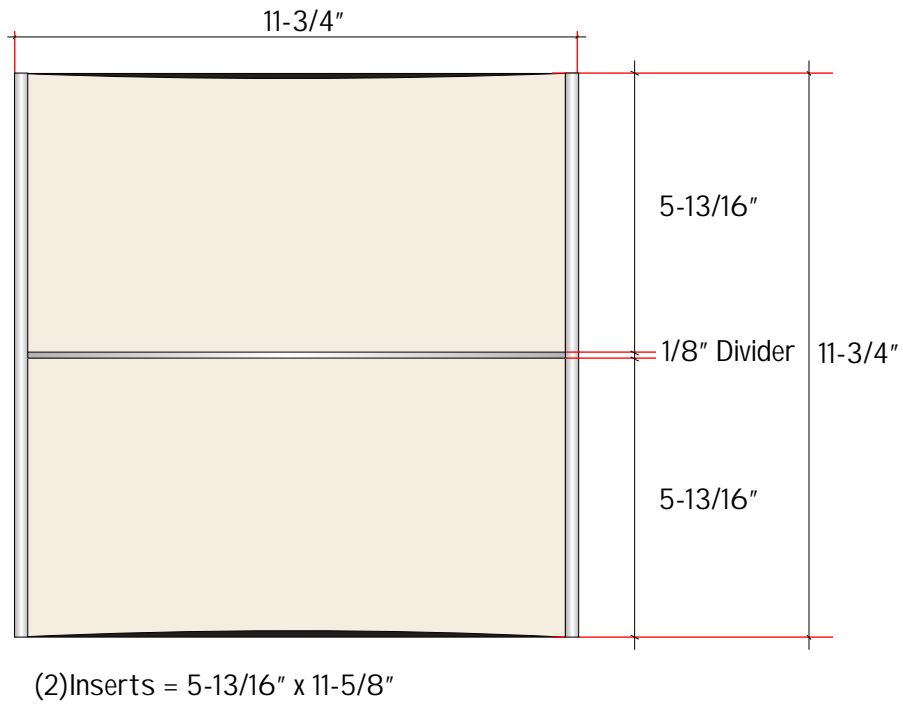

### Interior

This drawing and the ideas expressed remain the confidential property of INNERFACE. This drawing and its ideas are not to be reproduced, copied, or disclosed to any other person or entity without the express written consent of a representative or agent of INNERFACE.



# 8.86

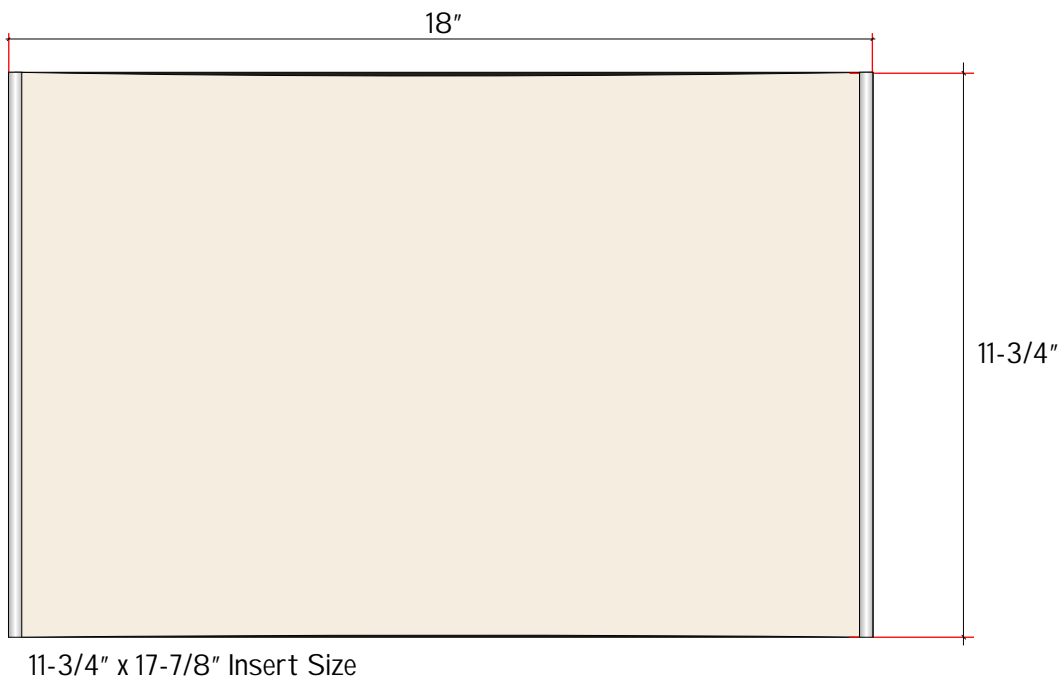

## Interior

This drawing and the ideas expressed remain the confidential property of INNERFACE. This drawing and its ideas are not to be reproduced, copied, or disclosed to any other person or entity without the express written consent of a representative or agent of INNERFACE.

# 9.0

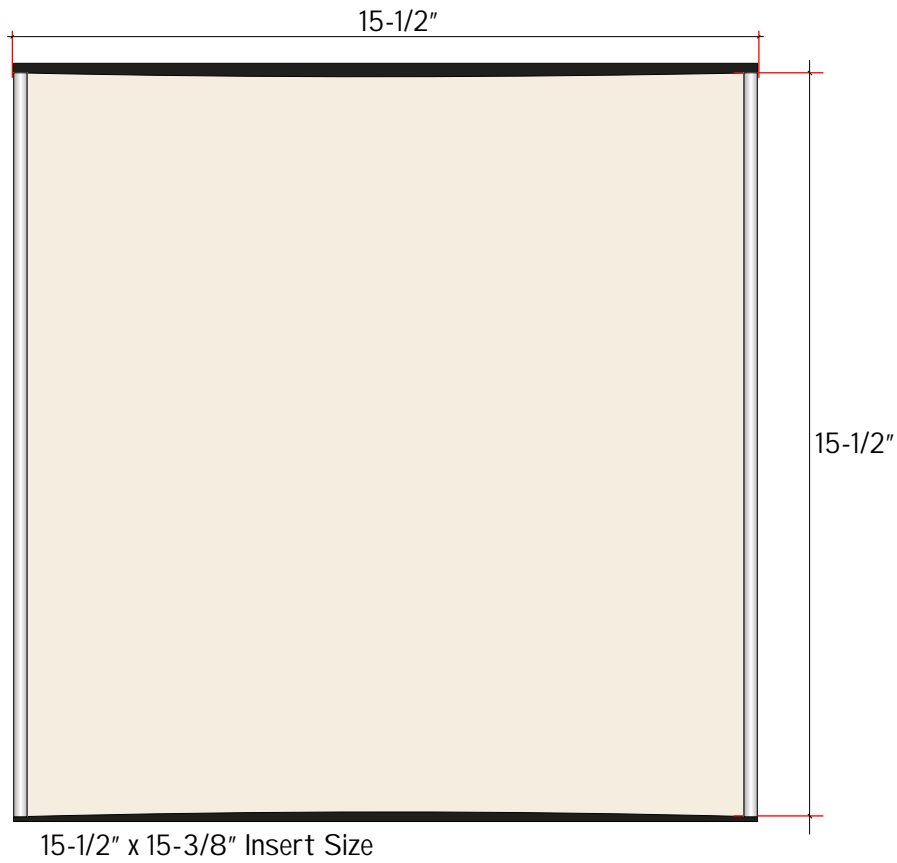

## Interior

This drawing and the ideas expressed remain the confidential property of INNERFACE. This drawing and its ideas are not to be reproduced, copied, or disclosed to any other person or entity without the express written consent of a representative or agent of INNERFACE.

# 9.1

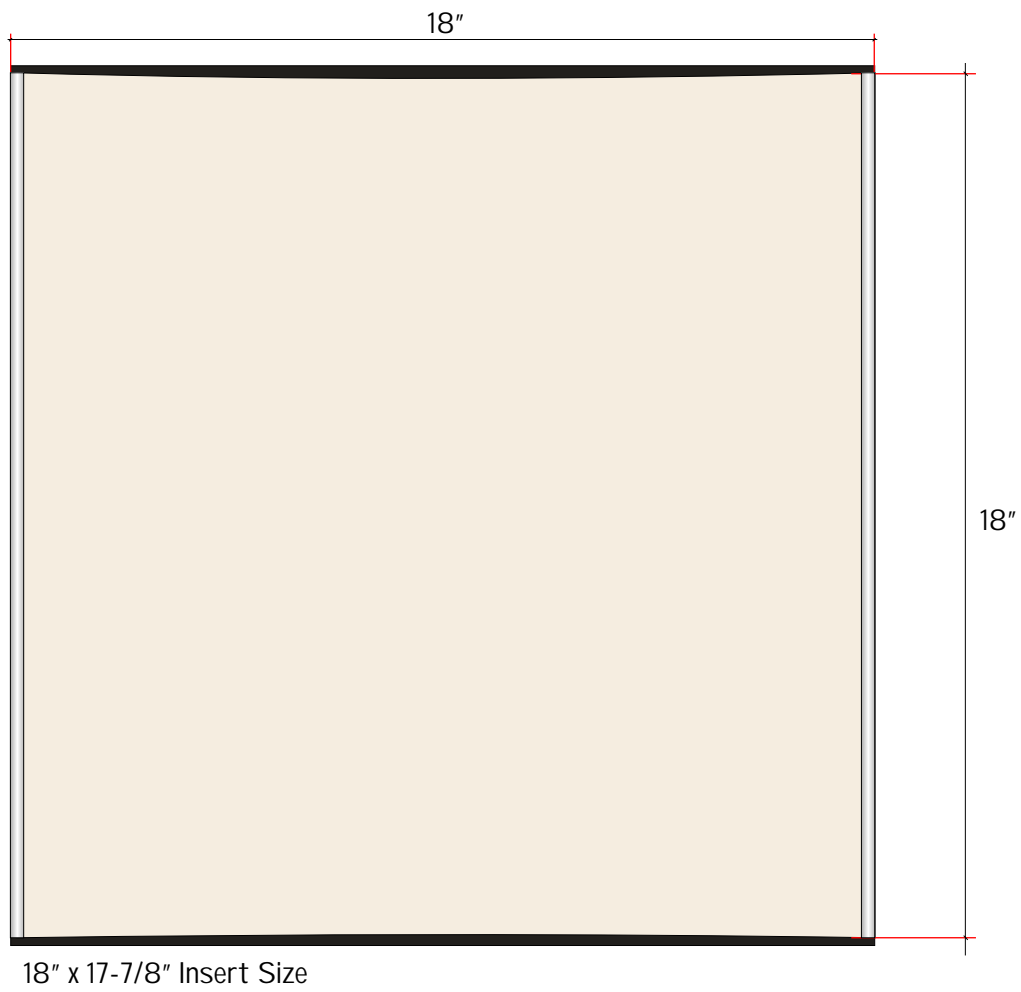

## Interior

This drawing and the ideas expressed remain the confidential property of INNERFACE. This drawing and its ideas are not to be reproduced, copied, or disclosed to any other person or entity without the express written consent of a representative or agent of INNERFACE.

# 10.0

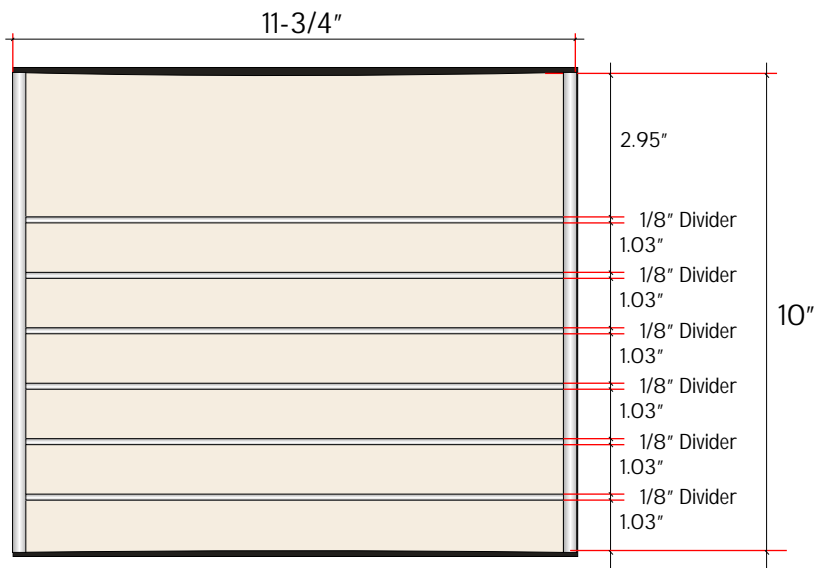

- (1)A Insert = 2.95" x 11-5/8"
- (5)B Inserts = 1.03" x 11-5/8"
- (1)C Insert = 1.03" x 11-5/8"

## Interior

This drawing and the ideas expressed remain the confidential property of INNERFACE. This drawing and its ideas are not to be reproduced, copied, or disclosed to any other person or entity without the express written consent of a representative or agent of INNERFACE.

# 10.1

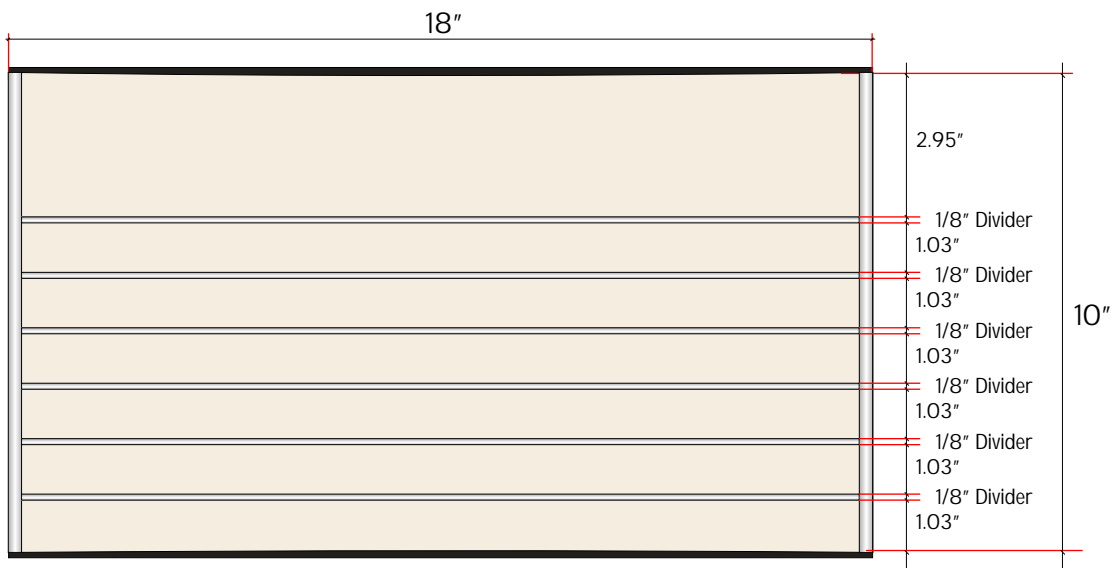

- (1)A Insert = 2.95" x 17-7/8"
- (5)B Inserts = 1.03" x 17-7/8"
- (1)C Insert = 1.03" x 17-7/8"

## Interior

This drawing and the ideas expressed remain the confidential property of INNERFACE. This drawing and its ideas are not to be reproduced, copied, or disclosed to any other person or entity without the express written consent of a representative or agent of INNERFACE.

# 11.0

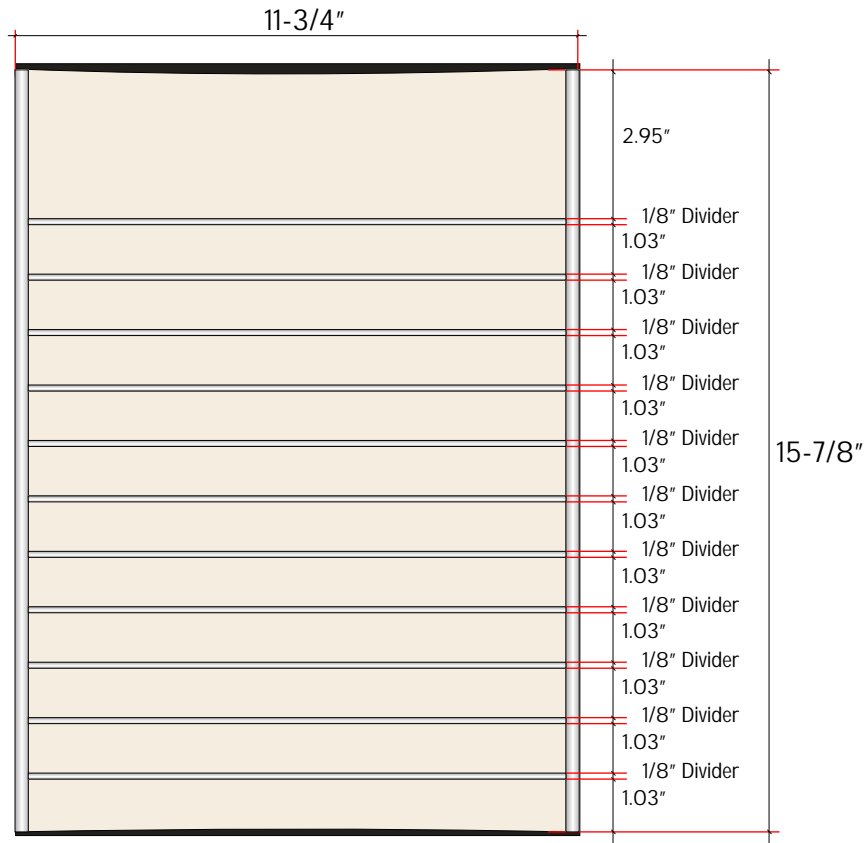

(1)A Insert = 2.95" x 11-5/8"

(10)B Inserts = 1.03" x 11-5/8"

(1)C Insert = 1.03" x 11-5/8"

## Interior

This drawing and the ideas expressed remain the confidential property of INNERFACE. This drawing and its ideas are not to be reproduced, copied, or disclosed to any other person or entity without the express written consent of a representative or agent of INNERFACE.

# 11.1

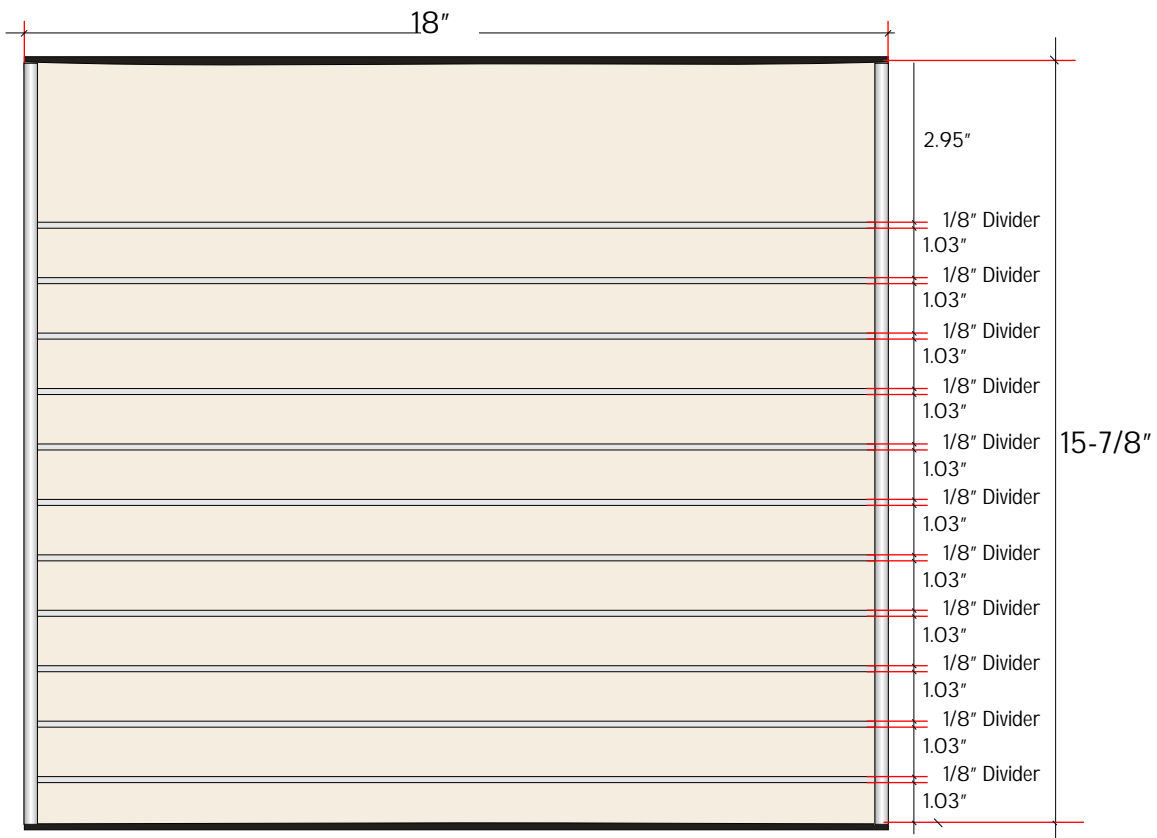

- (1)A Insert = 2.95" x 17-7/8"
- (10)B Inserts = 1.03" x 17-7/8"
- (1)C Insert = 1.03" x 17-7/8"

## Interior

This drawing and the ideas expressed remain the confidential property of INNERFACE. This drawing and its ideas are not to be reproduced, copied, or disclosed to any other person or entity without the express written consent of a representative or agent of INNERFACE.

# 12.0

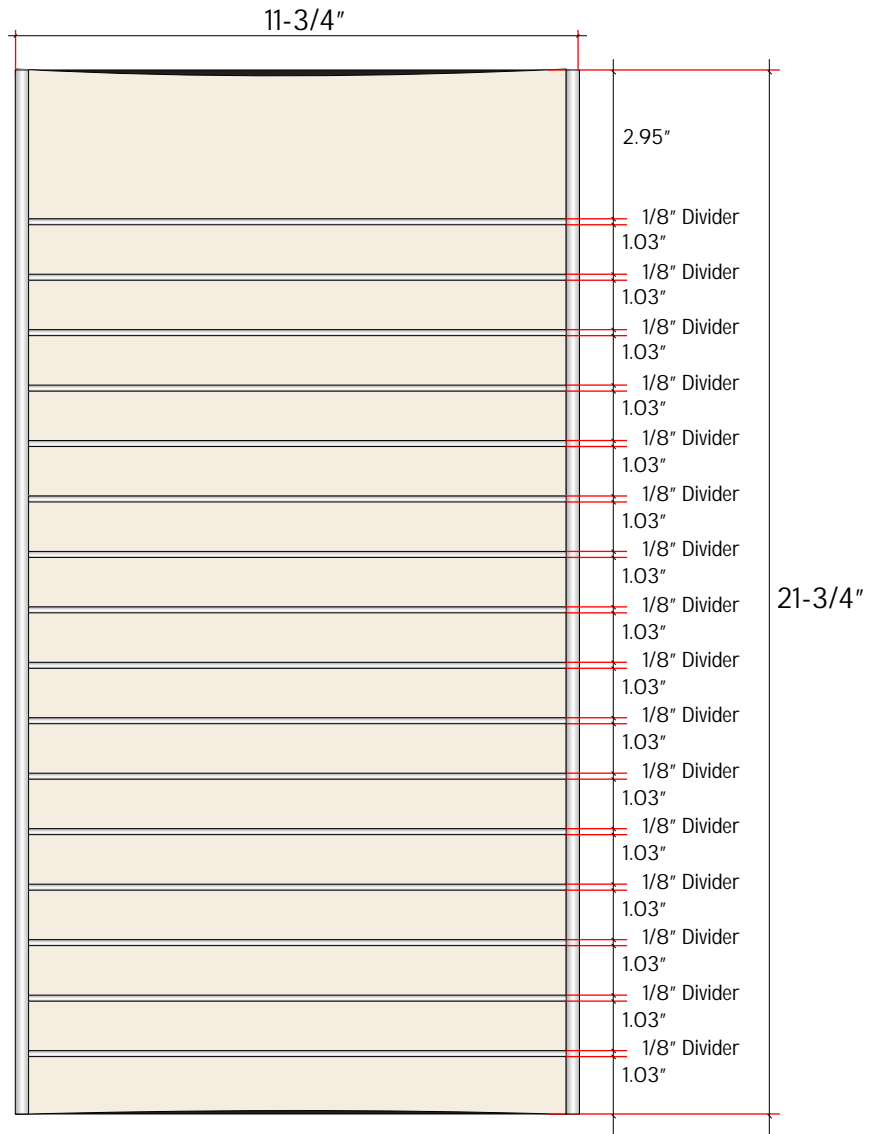

- (1)A Insert = 2.95" x 11-5/8"
- (15)B Inserts = 1.03" x 11-5/8"
- (1)C Insert = 1.03" x 11-5/8"

## Interior

This drawing and the ideas expressed remain the confidential property of INNERFACE. This drawing and its ideas are not to be reproduced, copied, or disclosed to any other person or entity without the express written consent of a representative or agent of INNERFACE.



# 12.1

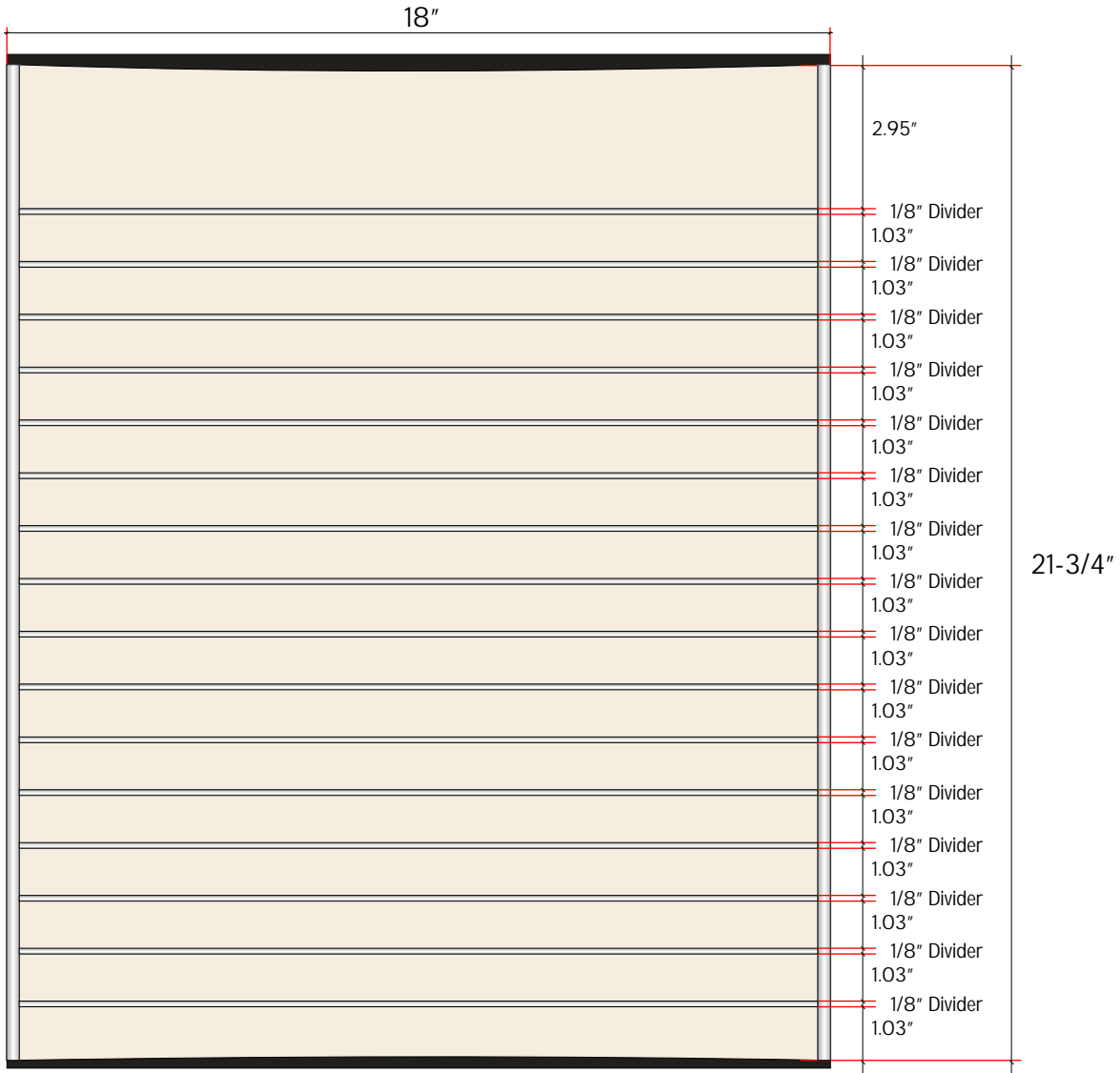

- (1)A Insert = 2.95" x 17-7/8"
- (15)B Inserts = 1.03" x 17-7/8"
- (1)C Insert = 1.03" x 17-7/8"

## Interior

This drawing and the ideas expressed remain the confidential property of INNERFACE. This drawing and its ideas are not to be reproduced, copied, or disclosed to any other person or entity without the express written consent of a representative or agent of INNERFACE.

# 13.0

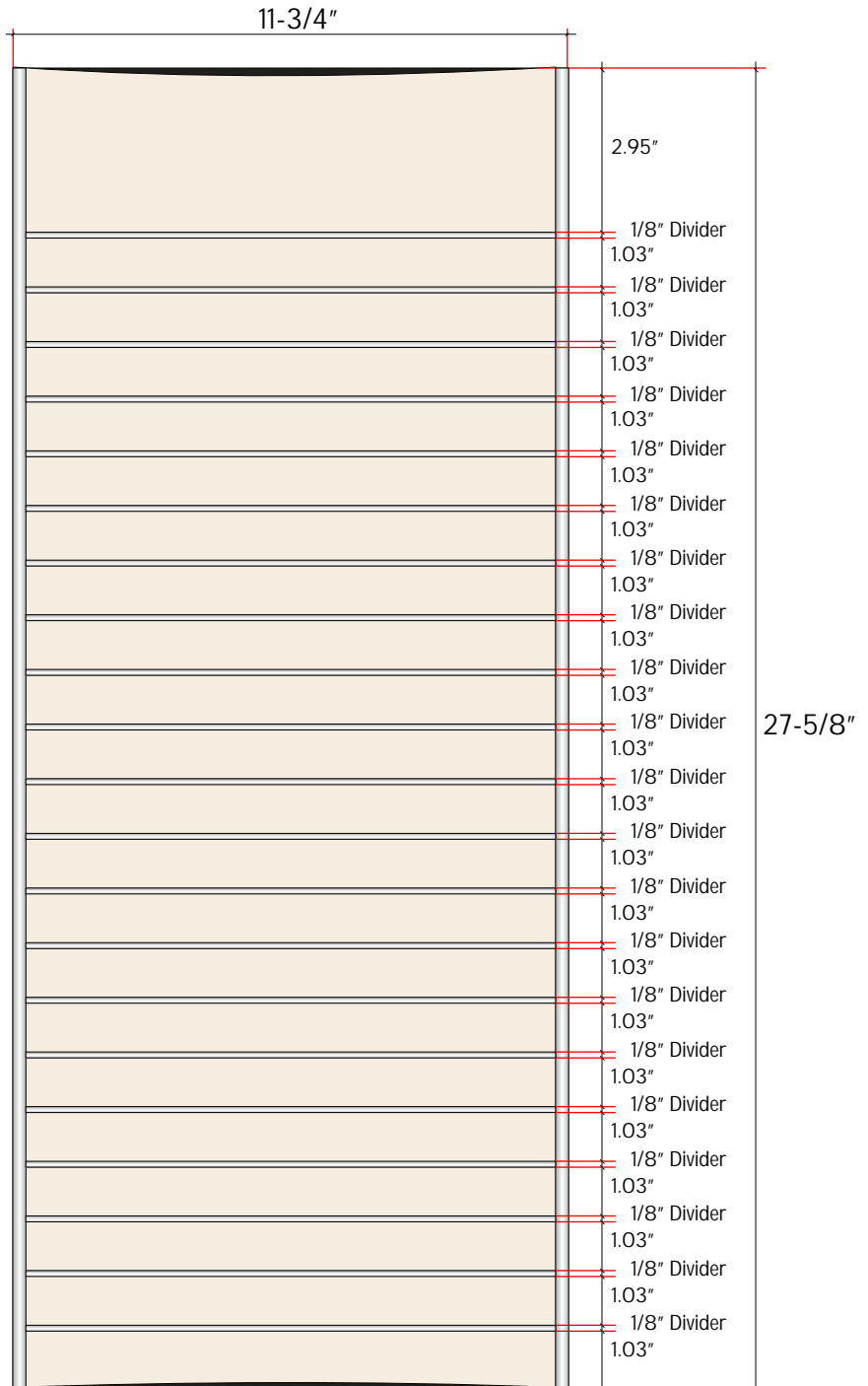

- (1)A Insert = 2.95" x 11-5/8"
- (20)B Inserts = 1.03" x 11-5/8"
- (1)C Insert = 1.03" x 11-5/8"

## Interior

This drawing and the ideas expressed remain the confidential property of INNERFACE. This drawing and its ideas are not to be reproduced, copied, or disclosed to any other person or entity without the express written consent of a representative or agent of INNERFACE.

# 13.1

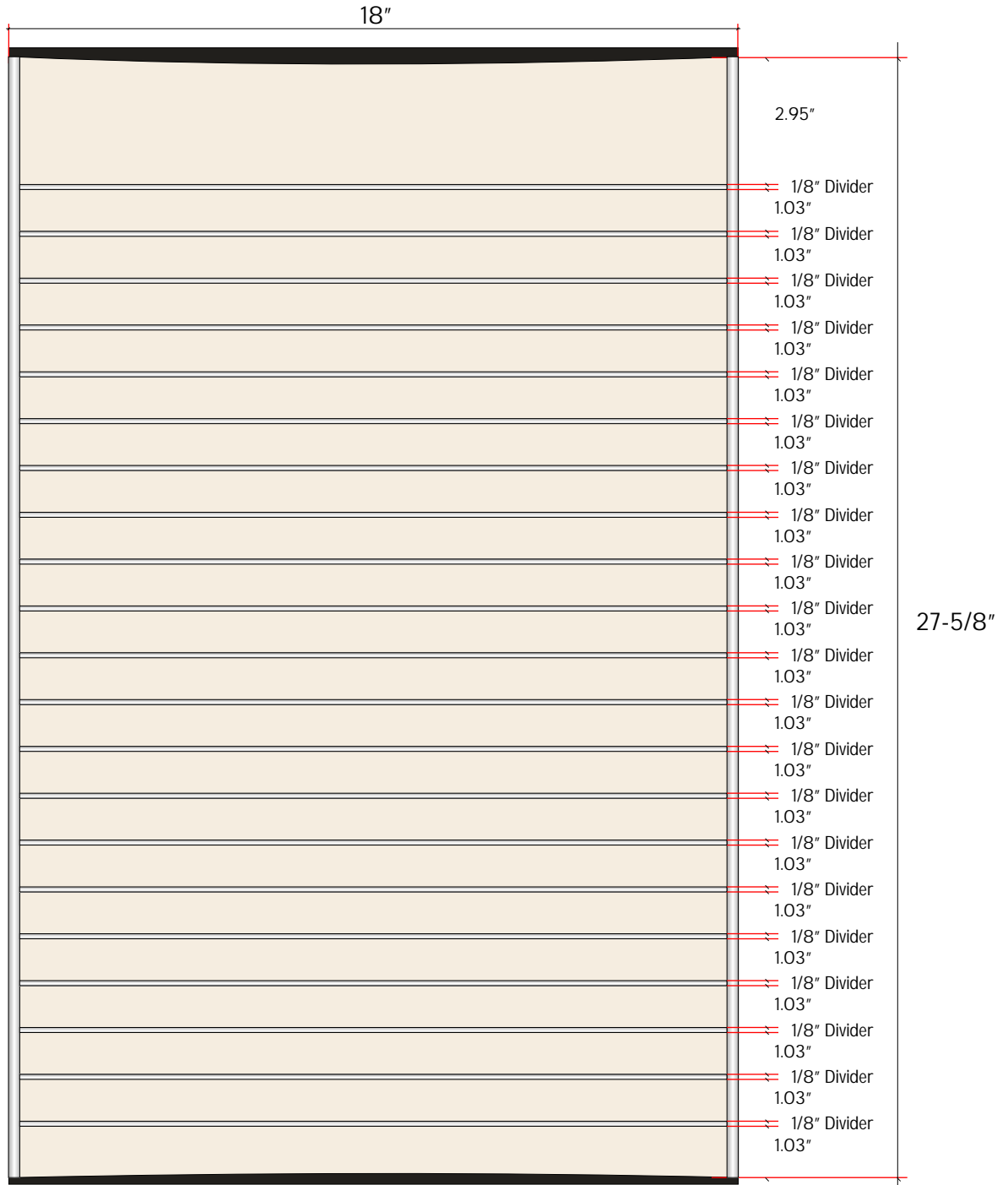

- (1)A Insert = 2.95" x 17-7/8"
- (20)B Inserts = 1.03" x 17-7/8"
- (1)C Insert = 1.03" x 17-7/8"

**Interior**

This drawing and the ideas expressed remain the confidential property of INNERFACE. This drawing and its ideas are not to be reproduced, copied, disclosed to any other person or entity without the express written consent of a representative or agent of INNERFACE.

# 14.0

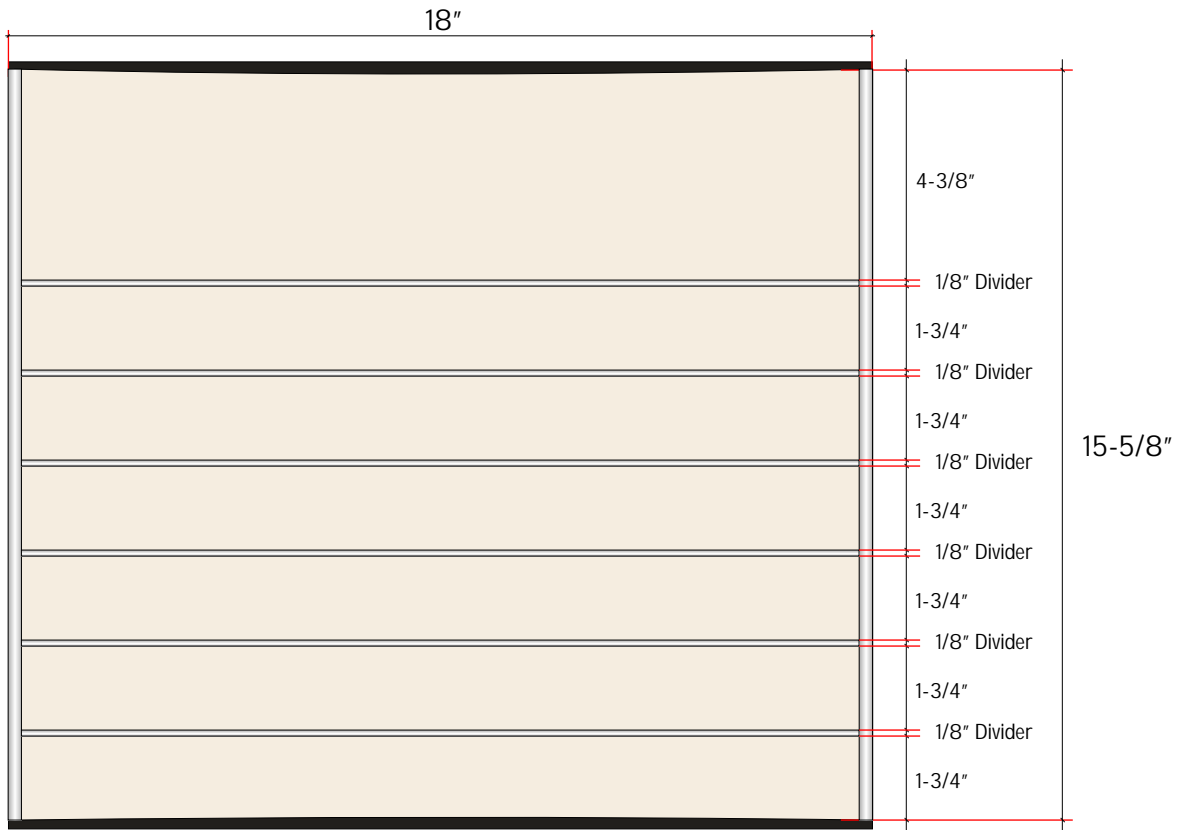

(1)A Insert = 4-3/8" x 17-7/8"

(5)B Inserts = 1-3/4" x 17-7/8"

(1)C Insert = 1-3/4" x 17-7/8"

## Interior

This drawing and the ideas expressed remain the confidential property of INNERFACE. This drawing and its ideas are not to be reproduced, copied, or disclosed to any other person or entity without the express written consent of a representative or agent of INNERFACE.

# 14.1

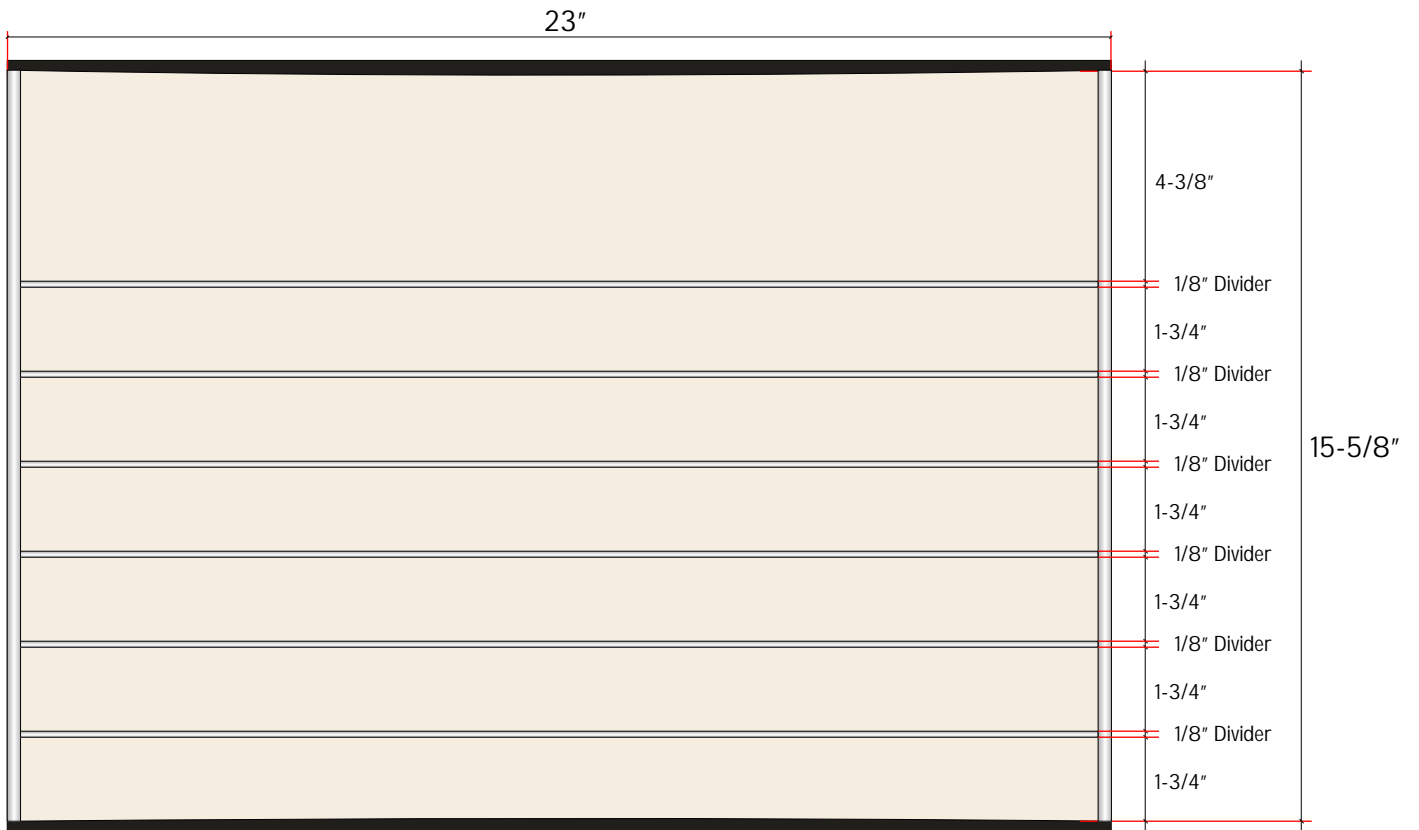

- (1)A Insert = 4-3/8" x 22-7/8"
- (5)B Inserts = 1-3/4" x 22-7/8"
- (1)C Insert = 1-3/4" x 22-7/8"

## Interior

This drawing and the ideas expressed remain the confidential property of INNERFACE. This drawing and its ideas are not to be reproduced, copied, or disclosed to any other person or entity without the express written consent of a representative or agent of INNERFACE.

# 15.0

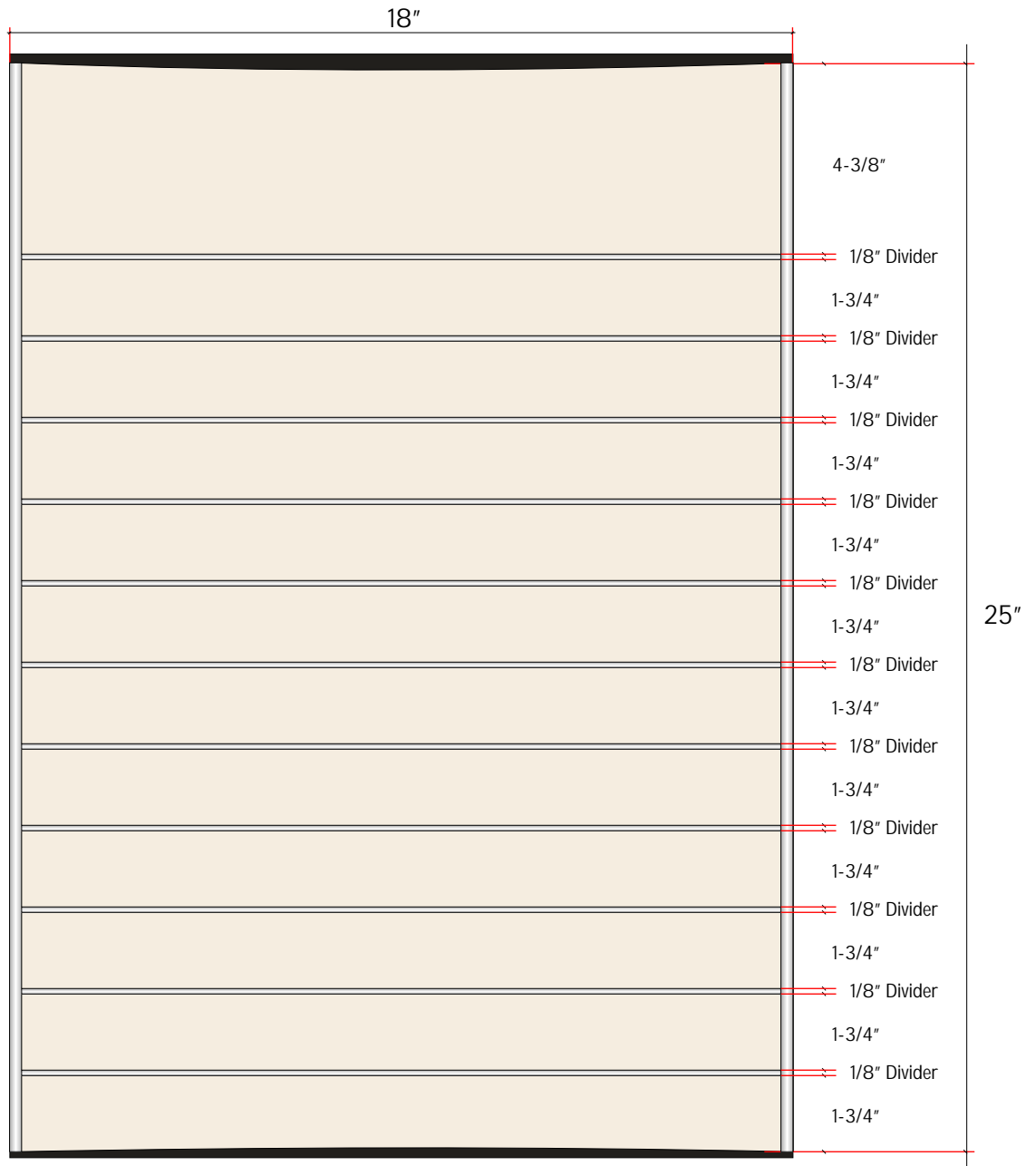

- (1)A Insert = 4-3/8" x 17-7/8"
- (10)B Inserts = 1-3/4" x 17-7/8"
- (1)C Insert = 1-3/4" x 17-7/8"

## Interior

This drawing and the ideas expressed remain the confidential property of INNERFACE. This drawing and its ideas are not to be reproduced, copied, or disclosed to any other person or entity without the express written consent of a representative or agent of INNERFACE.

# 15.1

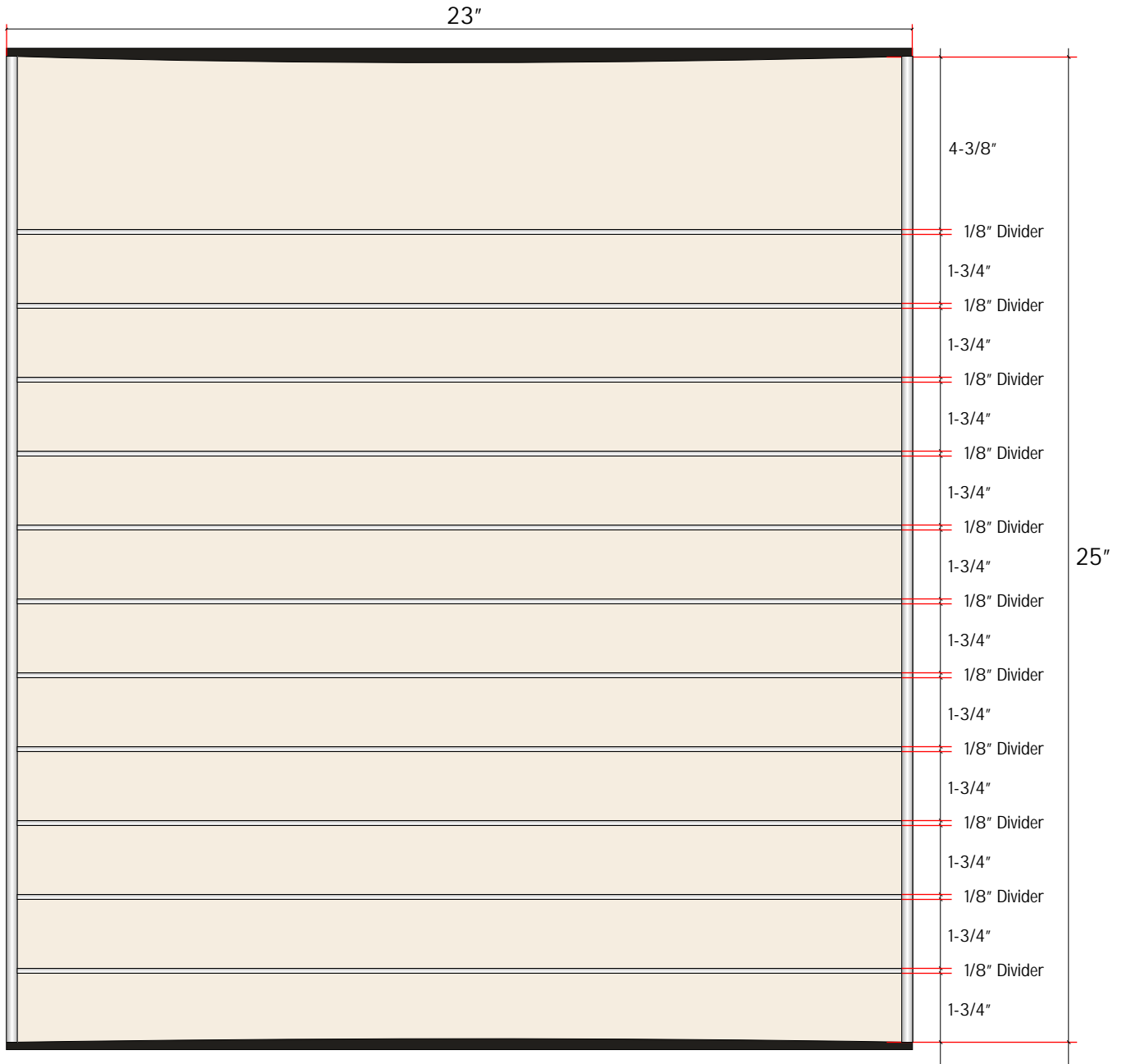

- (1)A Insert = 4-3/8" x 22-7/8"
- (10)B Inserts = 1-3/4" x 22-7/8"
- (1)C Insert = 1-3/4" x 22-7/8"

## Interior

This drawing and the ideas expressed remain the confidential property of INNERFACE. This drawing and its ideas are not to be reproduced, copied, or disclosed to any other person or entity without the express written consent of a representative or agent of INNERFACE.

# 16.0

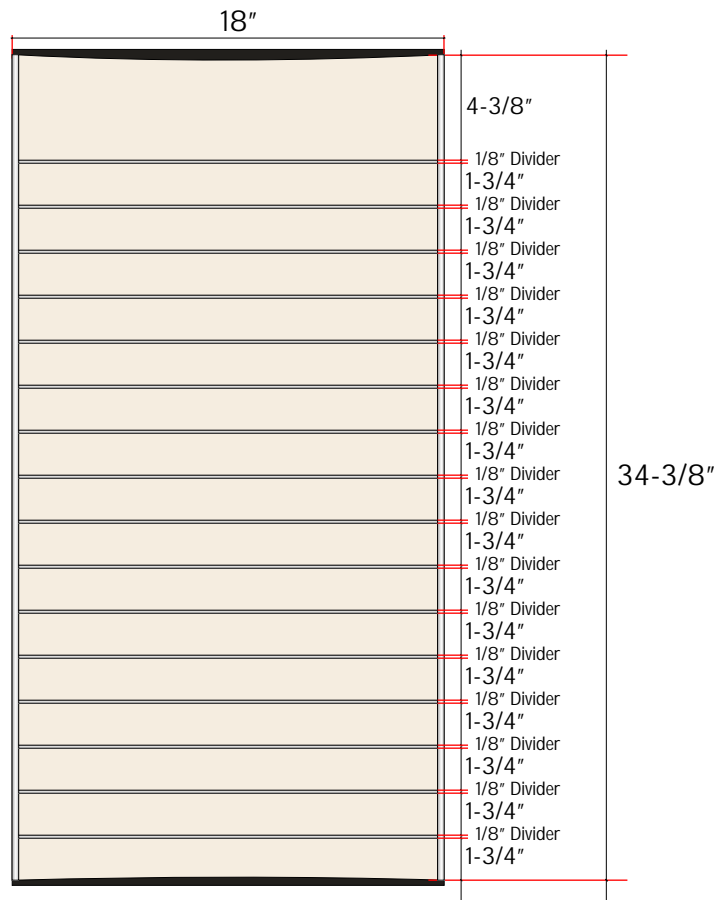

- (1)A Insert = 4-3/8" x 17-7/8"
- (15)B Inserts = 1-3/4" x 17-7/8"
- (1)C Insert = 1-3/4" x 17-7/8"

## Interior

This drawing and the ideas expressed remain the confidential property of INNERFACE. This drawing and its ideas are not to be reproduced, copied, or disclosed to any other person or entity without the express written consent of a representative or agent of INNERFACE.



# 16.1

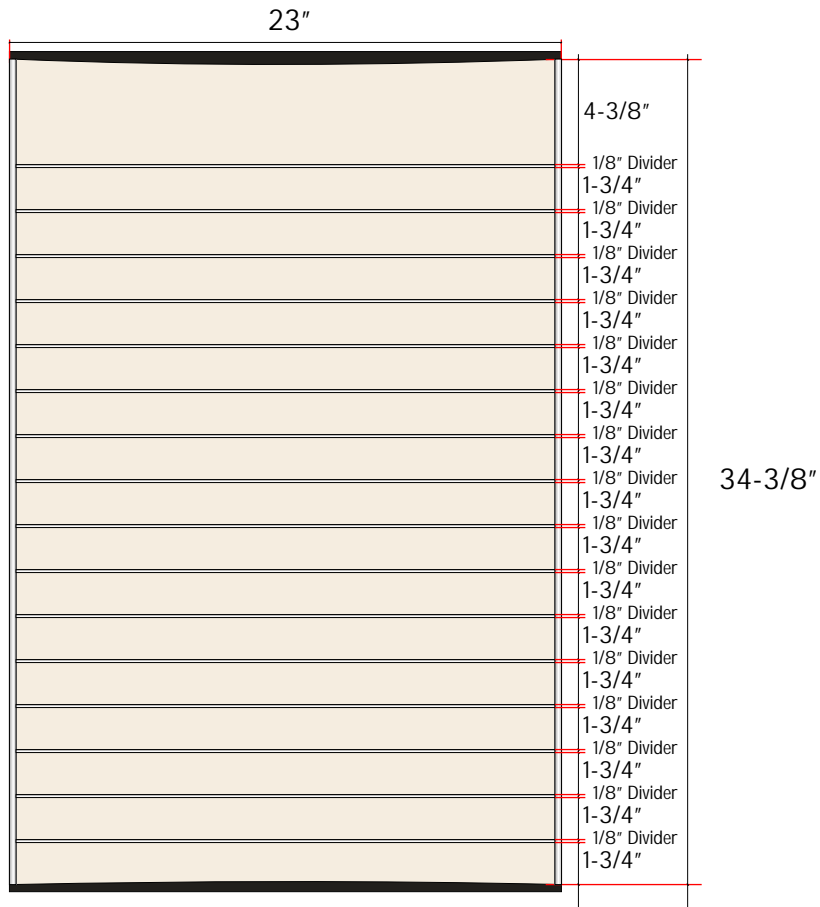

- (1)A Insert = 4-3/8" x 22-7/8"
- (15)B Inserts = 1-3/4" x 22-7/8"
- (1)C Insert = 1-3/4" x 22-7/8"

## Interior

This drawing and the ideas expressed remain the confidential property of INNERFACE. This drawing and its ideas are not to be reproduced, copied, or disclosed to any other person or entity without the express written consent of a representative or agent of INNERFACE.

# 29.0

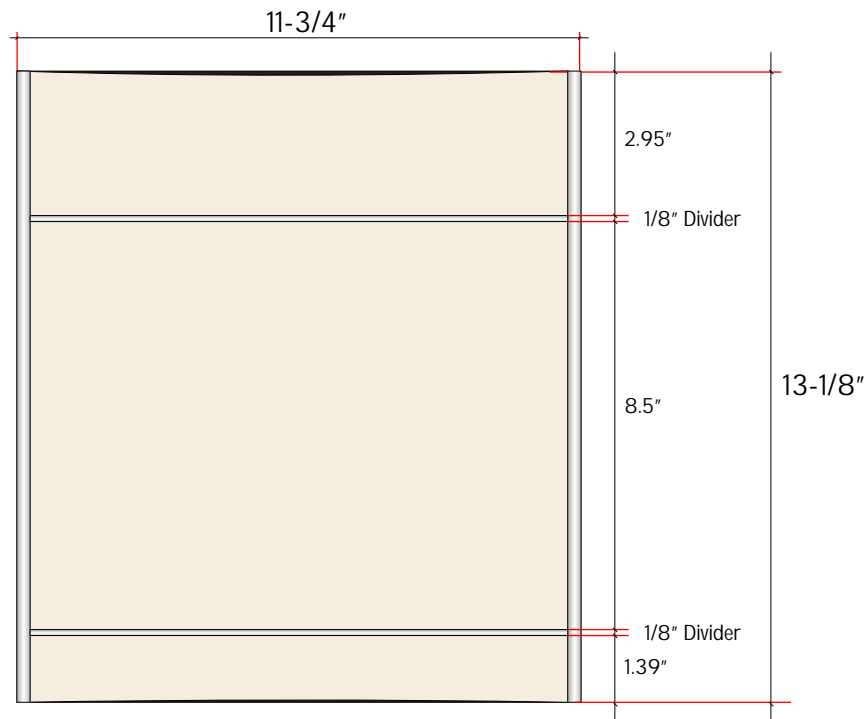

- (A) Insert = 2.95" x 11-5/8"
- (B) Insert = 8.5" x 11-5/8"
- (C) Insert = 1.39" x 11-5/8"

## Interior

This drawing and the ideas expressed remain the confidential property of INNERFACE. This drawing and its ideas are not to be reproduced, copied, or disclosed to any other person or entity without the express written consent of a representative or agent of INNERFACE.

# ARQ FREESTANDING MODULES

18"

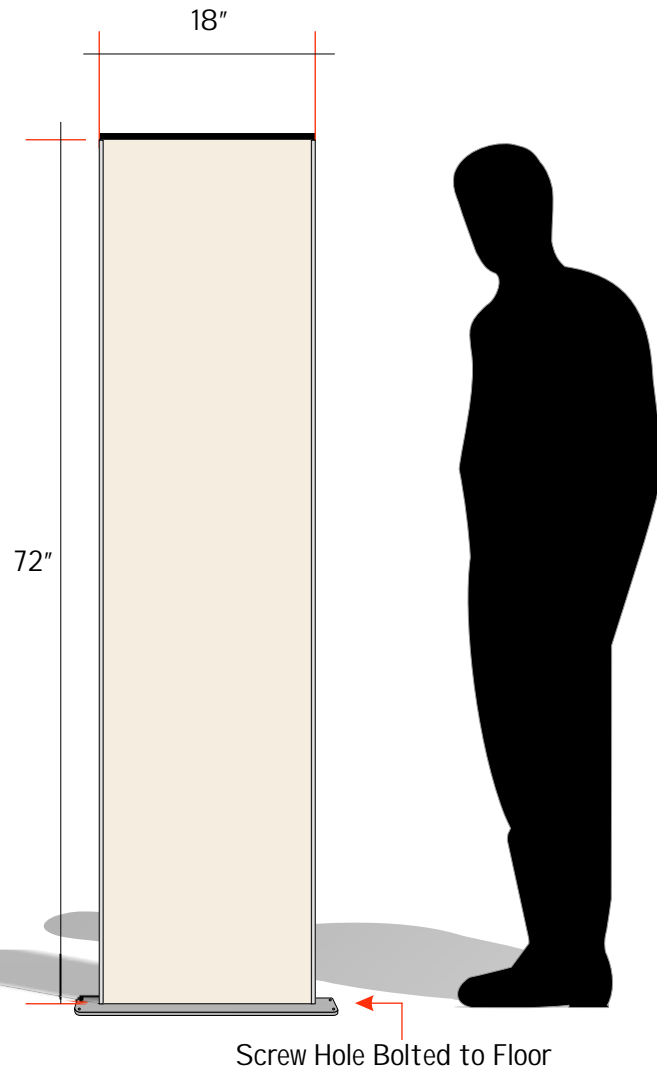
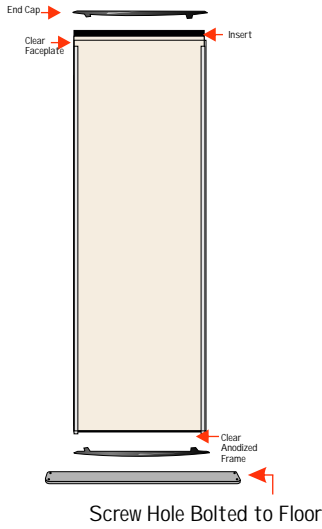

**Interior**

This drawing and the ideas expressed remain the confidential property of INNERFACE. This drawing and its ideas are not to be reproduced, copied, or disclosed to any other person or entity without the express written consent of a representative or agent of INNERFACE.

\* SIGN MUST BE DOUBLE SIDED.

23"

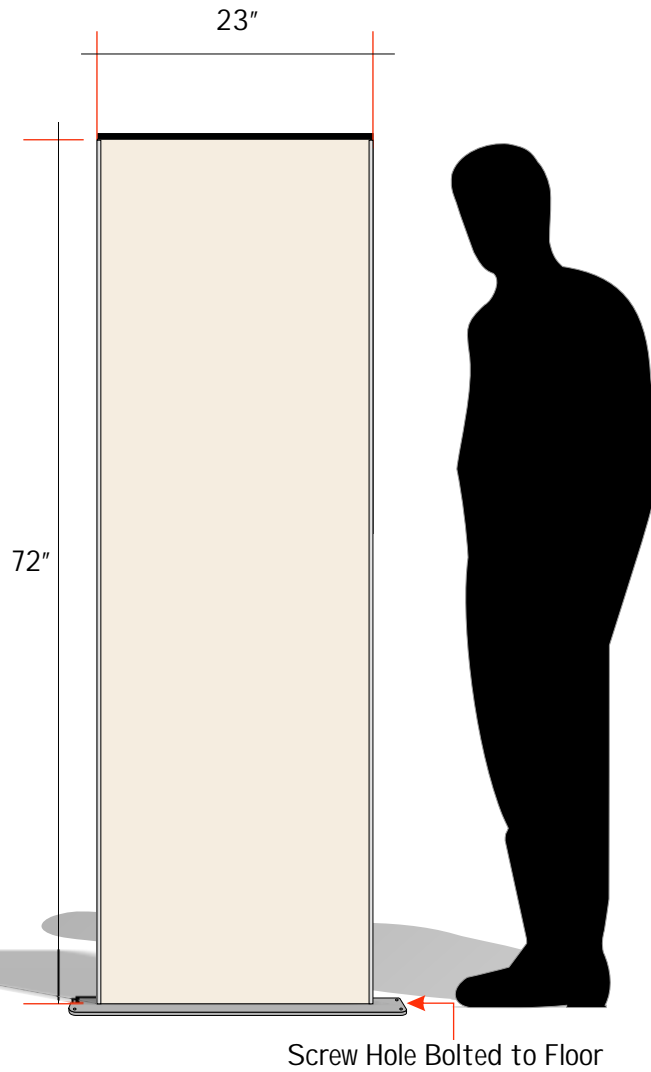
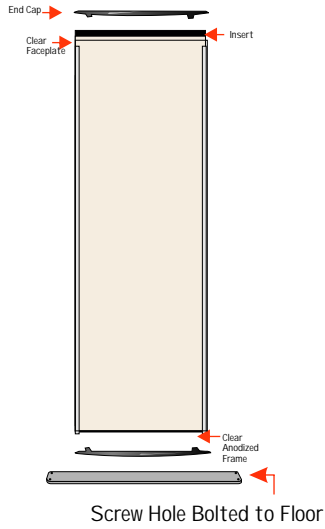

**Interior**

This drawing and the ideas expressed remain the confidential property of INNERFACE. This drawing and its ideas are not to be reproduced, copied, or disclosed to any other person or entity without the express written consent of a representative or agent of INNERFACE.

\* SIGN MUST BE DOUBLE SIDED.